

# **INSTRUCTION MANUAL**

**SOUND LEVEL METER**

**NA-83**



3-20-41 Higashimotomachi, Kokubunji, Tokyo 185-8533, Japan

<http://www.rion.co.jp/english/>



# Organization of This Manual

This manual describes the features, operation and other aspects of the Sound Level Meter NA-83. If the unit is used together with other equipment to configure a measurement system, consult the documentation of all other components as well. The following pages contain important information about safety. Be sure to read and observe these in full.

This manual contains the following sections.

## **Outline**

Gives basic information about the unit.

## **Controls and Functions**

Briefly identifies and explains the operation keys and connectors and all other parts of the unit. The display content is also explained.

## **Connections**

Explains how to connect the microphone and AC adapter.

## **Menu Setup**

Describes the various menu screens that are used for setting up the unit.

## **Calibration and Operation Check**

Explains how to calibrate the unit and verify correct operation.

## **Measurement**

Explains the basic procedure for making a measurement.

## **Connectors**

Provides information about the MIC. IN connector on the front panel, and the pin layout of the connector on the rear panel. A connection diagram is also shown.

## **Default Values**

Lists the settings that are active when power is supplied.

## Technical Reference

Provides information about the configuration of the unit, electrical and acoustic specifications, IEC compliance, and other items.

## Specifications

Lists the technical specifications of the unit.

## Serial Interface

### Transfer Format and Protocol

Provides information about connection to a computer, and the procedures for command reception and data transfer.

### Commands

Lists the commands that are available to control the unit and retrieve measurement data.

\* All company names and product names mentioned in this manual are trademarks or registered trademarks of their respective owners.

# FOR SAFETY

In this manual, important safety instructions are specially marked as shown below. To prevent the severe damage to the unit or peripheral equipment, make sure that all instructions are fully understood and observed.

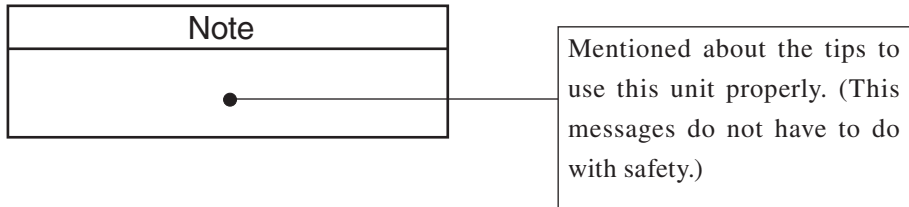
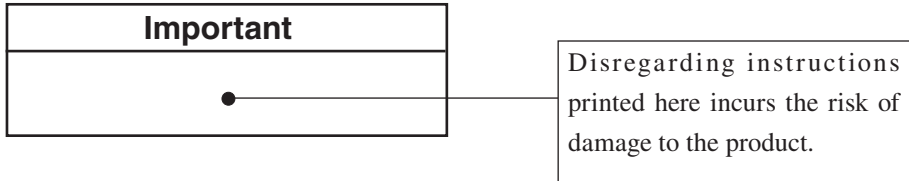

# Precautions

- Operate the unit only as described in this manual.
- The NA-83 is a precision instrument. Protect it from shocks and vibrations. Take special care not to touch the microphone diaphragm. The diaphragm is a very thin metal film which can easily be damaged.
- Use only the microphone with the number as shown on the name plate of the unit.
- Do not use the unit in an environment where the specifications for ambient temperature and humidity may be exceeded (temperature range -10 to +50°C, relative humidity 10 to 90%).
- Protect the unit from water, dust, extreme temperatures, humidity, and direct sunlight during storage and use. Also keep the unit away from air with high salt or sulphur content, gases, and stored chemicals.
- Always turn the unit off after use. When disconnecting cables, always grasp the plug and do not pull the cable.
- Before using the unit and before putting it away, always check that the microphone grid has not become loose. If this has happened, refasten the microphone grid firmly and then use or store the unit.
- Clean the unit only by wiping it with a soft, dry cloth or, when necessary, with a cloth lightly moistened with water. Do not use any solvents, cleaning alcohol or chemical cleaning agents.
- Do not try to disassemble or alter the unit. Otherwise type certification will become invalid. In case of an apparent malfunction, do not attempt any repairs. Note the condition of the unit clearly and contact the supplier.
- Do not tap the LCD panel or other surfaces of the unit with a pointed object such as a pencil, screwdriver, etc.
- Take care that no conductive objects such as wire, metal scraps, conductive plastics etc. can get into the unit.

- To ensure continued accuracy, have the unit checked and serviced at regular intervals.
- Dispose of the unit according to national and local regulations at the place of use.

To conform to the EU requirement of the Directive 2002/96/EC on Waste Electrical and Electronic Equipment, the symbol mark on the right is shown on the instrument.



The product described in this manual is in conformity with the following standards;

EN61326-1:2006/IEC 61326-1:2005

Electrical equipment for measurement control and laboratory use.

RION Co., Ltd.

3-20-41 Higashimotomachi, Kokubunji, Tokyo 185-8533, Japan

RION Co., Ltd. Europe Representative Office Schaepmanlaan 66, 4623 XZ,  
Bergen op Zoom, The Netherlands

# Contents

FOR SAFETY.....	iii
Outline .....	1
Controls and Functions .....	2
Front panel .....	2
Right side panel .....	3
Left side panel .....	5
Rear panel .....	6
Display panel .....	7
Outdoor Microphone MS-11 .....	10
Connections .....	11
Using the All-Weather Windscreen WS-13 .....	11
Microphone connection .....	16
Mounting the All-Weather Windscreen WS-13 on a tripod .....	17
Mounting on All-Weather Windscreen Tripod ST-81 .....	17
Mounting on All-Weather Windscreen Tripod ST-88 .....	18
Power on/off switching (AC adapter connection) .....	21
Power on .....	21
Power off .....	21
Connection of AC/DC OUT connector .....	22
Menu Setup .....	23
Microphone integrated sound source setup .....	23
Frequency weighting setup .....	24
Time weighting setup .....	25
AC/DC OUT setup .....	26
Windscreen correction setup screen .....	27
Calibration and Operation Check .....	28
Calibration with microphone integrated sound source .....	28
Atmospheric pressure correction .....	29
Acoustic calibration with Sound Calibrator NC-74 .....	30
Operation check with microphone integrated sound source .....	32



Measurement .....	33
Measurement of time-weighted sound level $L_p$ (instantaneous value) .....	33
Measurement of maximum time-weighted sound level $L_{max}$ .....	35
Connectors .....	37
MIC. IN connector .....	37
Rear-panel connector .....	38
Wiring diagram .....	39
DC power supply .....	40
Reset control .....	40
Default Values .....	41
Technical Reference .....	42
Microphone and Preamplifier .....	42
Construction and Operation Principle.....	42
Thermal Characteristics .....	43
Humidity Characteristics.....	43
Preamplifier.....	44
Integrated sound source .....	44
Condensation-preventing heater .....	44
Influence of Microphone Extension Cable .....	45
Frequency Weighting Network.....	46
RMS Detection Circuit and Time Weighting .....	47
Influence of Background Noise.....	50
Description for IEC 61672-1 .....	51
IEC61672-1 (JIS C 1509-1) Frequency Response .....	59
Reference incidence direction and reference point position .....	61
Frequency Response .....	62
Effect of All-Weather Windscreen WS-13 .....	62
The greatest susceptibility configuration for radio frequency fields .....	64
Frequency response adjustment data for periodic test .....	64
The lower and upper limits of the linear operating range .....	65
Directional Characteristics .....	66
Random incidence response correction.....	69
Statement of conforming to the basic statement.....	69
Specifications .....	70

## Serial Interface

Transfer Format and Protocol .....	80
Transfer protocol .....	80
Local Mode/Remote Mode .....	80
Transfer codes .....	81
Transfer format .....	82
Block reception processing .....	83
Communication cutoff .....	88
Ratings .....	88
Commands .....	89
Command list .....	89
Command format .....	90
Error codes .....	91
Command send example .....	91
Command description .....	92
Measurement parameter related commands .....	92
Calibration/operation check related commands .....	95
Measurement data retrieval related commands .....	96
Setting and information related commands .....	98
Example for control via external commands .....	99

# Outline

The NA-83 is a Sound Level Meter that conforms to Measurement Law requirements for precision sound level meters, IEC 61672-1:2002 Class 1 (JIS C 1509-1:2005 Class 1). It features a wide measurement range for sound levels from 28 dB to 138 dB without range switching. Measurement values are displayed on the integrated LCD panel.

## Features

- Combination with Outdoor Microphone MS-11 with built-in heater and All-Weather Windscreen WS-13 allows continuous long-term outdoor use.
- Built-in sound source of Outdoor Microphone MS-11 allows acoustic calibration by remote operation.
- Windscreen correction feature of NA-83 ensures compliance with Measurement Law requirements for precision sound level meters, IEC 61672-1:2002 Class 1 (JIS C 1509-1:2005 Class 1) also when All-Weather Windscreen WS-13 is mounted.
- AC/DC output connector provides either AC or DC output signal (switchable).
- Serial communication enables data transfer and measurement control. Data for time-weighted sound level  $L_p$  sampling value, maximum sound level  $L_{\max}$ , minimum sound level  $L_{\min}$ , and time-average sound level  $L_{\text{eq}}$  are sent simultaneously at intervals of 100 ms.

# Controls and Functions

## Front panel

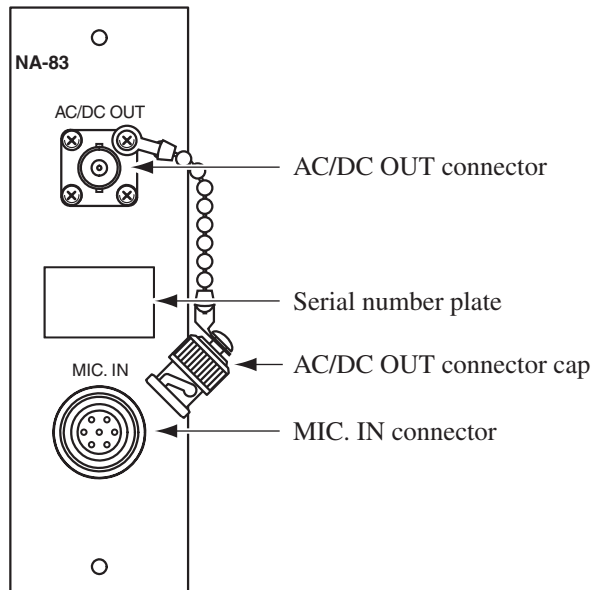

### AC/DC OUT connector

Supplies either an AC or DC output signal (selectable). For details on the AC/DC OUT setup screen, see page 26.

AC OUT is a frequency based signal using C weighting.

DC OUT is a level signal with logarithmic compression, based on the currently selected frequency weighting and time weighting settings.

### Serial number plate

Shows the model type and serial number about the unit and microphone.

### AC/DC OUT connector cap

This cover protects the connector from dust and other contamination. It should be in place when not using the connector.

### MIC. IN connector

This is the microphone connector. The Outdoor Microphone MS-11 via its extension cable is to be connected here.

## Right side panel

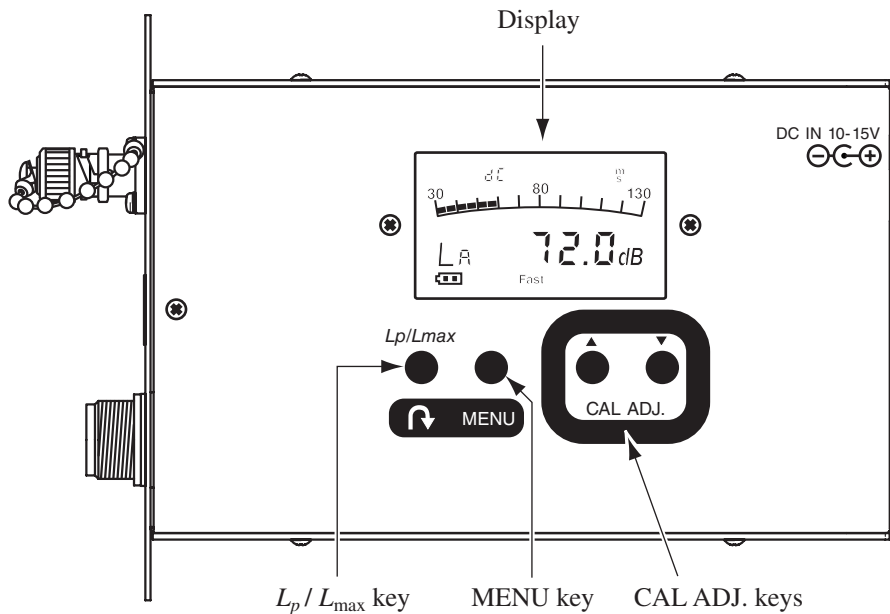

### $L_p/L_{max}$ key

Determines whether sound level measurement is for instantaneous value or maximum hold value. When a menu screen has been called up with the MENU key, the key serves for selecting a setting item.

### MENU key

Each push of this key cycles through the menu screens listed below.

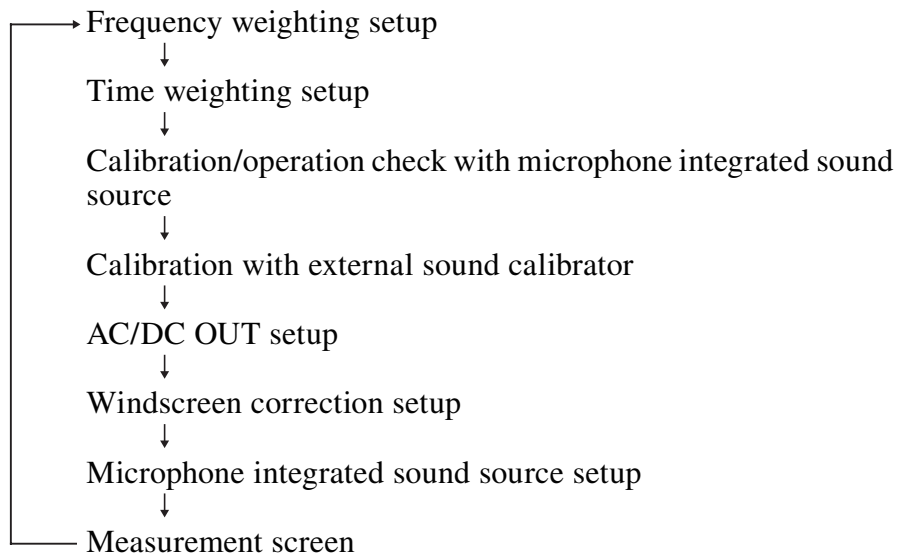

## CAL ADJ. keys

When the “Calibration/operation check with microphone integrated sound source” screen and “Calibration with external sound calibrator” screen is used, these keys serve to adjust the calibration level.

When another menu screen is shown, the keys serve for returning to the measurement screen. While the measurement screen is shown, the keys have no function.

## Display

This LCD panel shows the sound level as well as information about settings, under-range and over-range condition, and other items.

## Left side panel

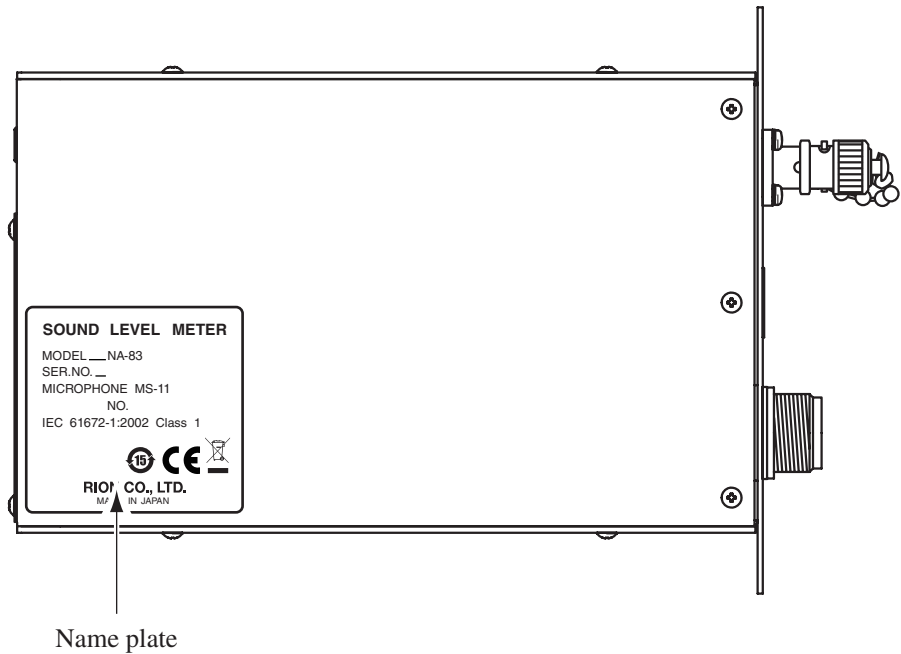

### Name plate

Shows information about the model name, type, serial number, microphone serial number, standard compliance, etc.

## Rear panel

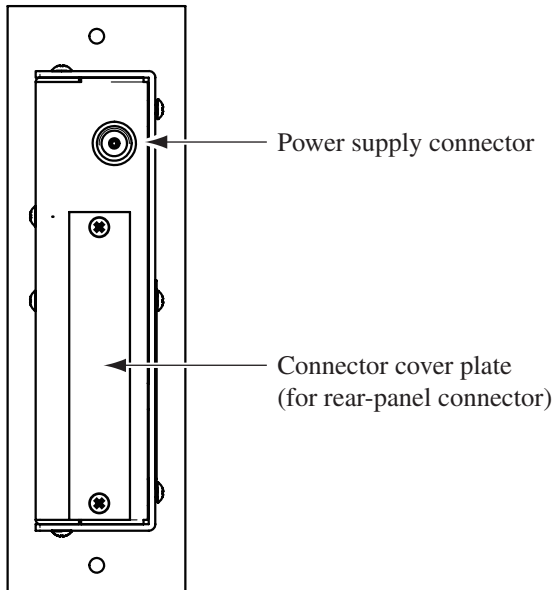

### Power supply connector

A DC source rated for 10 to 15 V can be connected here. The AC adapter RC45-12L should be used.

### Connector cover plate

Protects the rear-panel connector.

For serial communication, remove this cover and plug the supplied communication connector (KEL 8300-032-281) into the rear-panel connector.



## Display panel

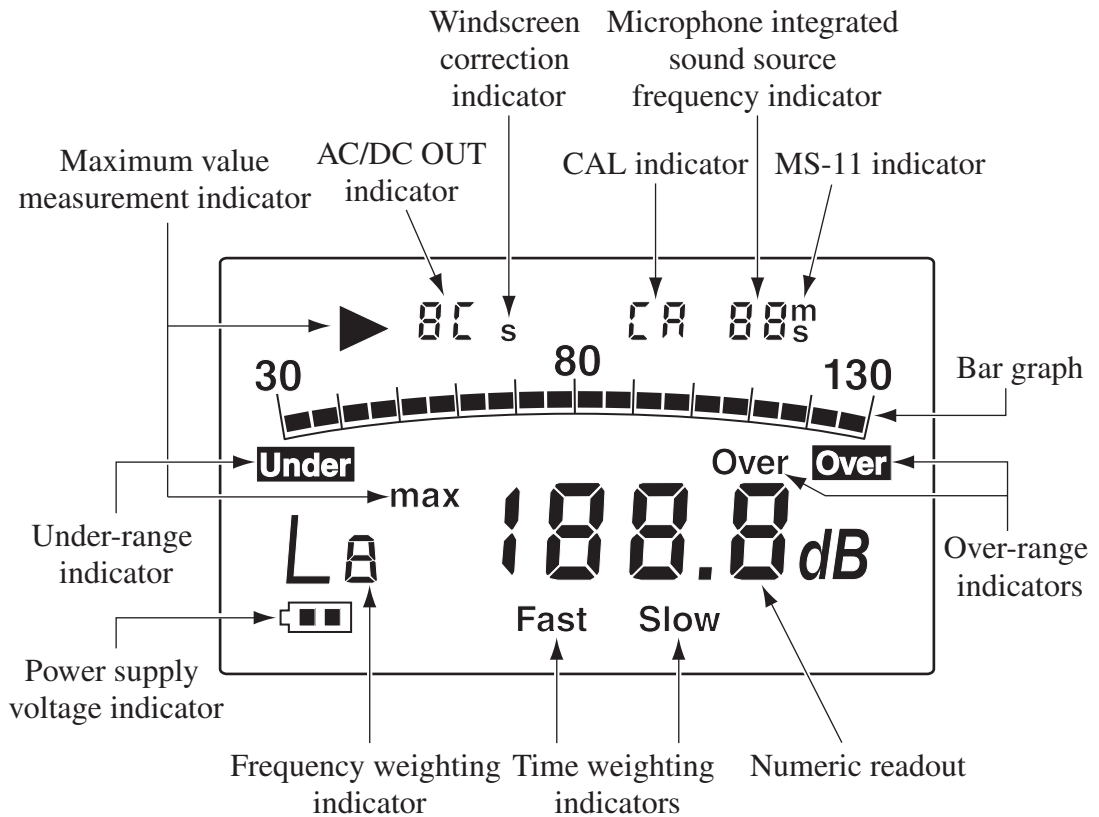

### AC/DC OUT indicator

Shows the AC/DC OUT setting.

AC: AC OUT is selected.

dC: DC OUT is selected.

### Windscreen correction indicator

Appears when the windscreen correction has been set to ON.

This setting can be made at the Windscreen correction setup screen (page 27).

### CAL indicator

This indicator is shown constantly when “Calibration with microphone integrated sound source” (page 28) or “Operation check with microphone integrated sound source” (page 32) is carried out.

When “Acoustic calibration with Sound Calibrator NC-74” (page 30) is carried out, the indicator flashes.

## Microphone integrated sound source frequency indicator

When “Calibration with microphone integrated sound source” or “Operation check with microphone integrated sound source” is carried out, the frequency of the integrated sound source is shown here. The following four indications are available.

“25”: 250 Hz    “50”: 500 Hz    “1”: 1 kHz    “4”: 4 kHz

## MS-11 indicator

This indicator is shown when the integrated sound source of the Outdoor Microphone MS-11 can be used.

The sound source is enabled by setting it to ON on the microphone integrated sound source setup screen (page 23).

## Bar graph

Shows the instantaneous value of the sound level (updated every 100 ms).

## Over-range indicators

Indicate that the sound level signal has exceeded the upper limit of the allowable range.

If the instantaneous value of the sound level has exceeded the range, the right-side **Over** indicator is shown for at least 1 second.

If the sound level during maximum value measurement has exceeded the range at least once, the left-side **Over** indicator appears and is held until the end of maximum value measurement.

## Numeric readout

Normally, the sound level is shown here as a dB value.

## Time weighting indicators

Show the selected time weighting.

“Fast”: Time weighting F (Fast-response)

“Slow”: Time weighting S (Slow-response)

## Frequency weighting indicator

Show the selected frequency weightings.

“A”: A weighting

“C”: C weighting

“p”: Z weighting

### Power supply voltage indicator

Shows the voltage of the power supplied to the unit, as follows.

[ ■ ■ ] (2 segments on): approx. 11.3 to 15 V

[ ■ ] (1 segment on): approx. 9.8 to 11.3 V

[ ■ ■ ] (flashing): lower than approx. 9.8 V

### Under-range indicator (UNDER)

When the sound level signal has dropped below the lower limit of the allowable range, this indicator is shown for at least one second.

### Maximum value measurement indicator

To make a maximum value measurement, press the  $L_p/L_{\max}$  key so that this indicator is shown.

## Outdoor Microphone MS-11

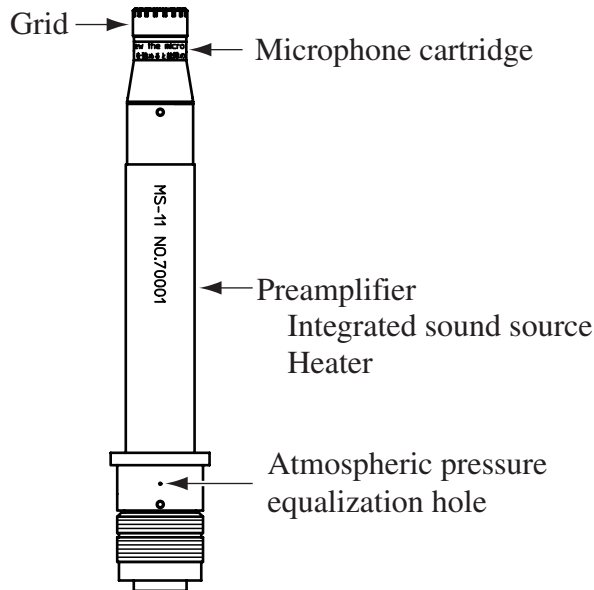

### Integrated sound source

This source is driven by a signal from the NA-83 and generates a calibration tone (1 kHz, 114 dB, at an atmospheric pressure of 101.3 kPa) within the microphone cartridge. It can be used to calibrate and verify operation of the system consisting of the microphone and sound level meter.

### Heater

This device serves to prevent internal condensation in the MS-11. The heat value is about 0.9 W. It is integrated in the preamplifier section.

### Atmospheric pressure equalization hole

This hole of 0.5 mm diameter equalizes differences in air pressure inside and outside of the MS-11.

#### Important

Never remove the microphone cartridge.

Do not remove the grid. Otherwise the diaphragm may become deformed or damaged, which will result in impaired performance.

Do not block the atmospheric pressure equalization hole with tape or similar. If pressure cannot be equalized, microphone performance will be impaired.

# Connections

## Using the All-Weather Windscreen WS-13

Important
Disconnect the power before making any connections (see page 21).
Use only the microphone whose serial number is shown on the name plate of the unit.

The All-Weather Windscreen WS-13 and Microphone Extension Cable EC-04 series are sold separately as options.

In addition, one of the following tripods can be used for installation.

- All-Weather Windscreen Tripod ST-81, ST-88

(Connecting the microphone extension cable)

1. Insert the microphone extension cable through the cable cutout on the side of the mounting tube.

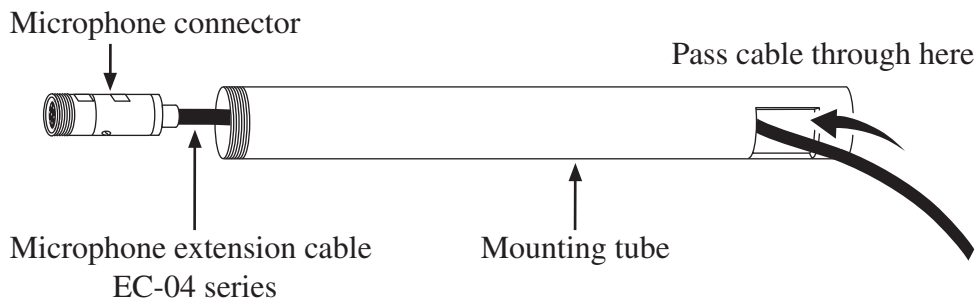

2. Attach the supplied ferrite cores to the microphone extension cable. Attach two cores near the microphone connector end and one core near the sound level meter connector end.

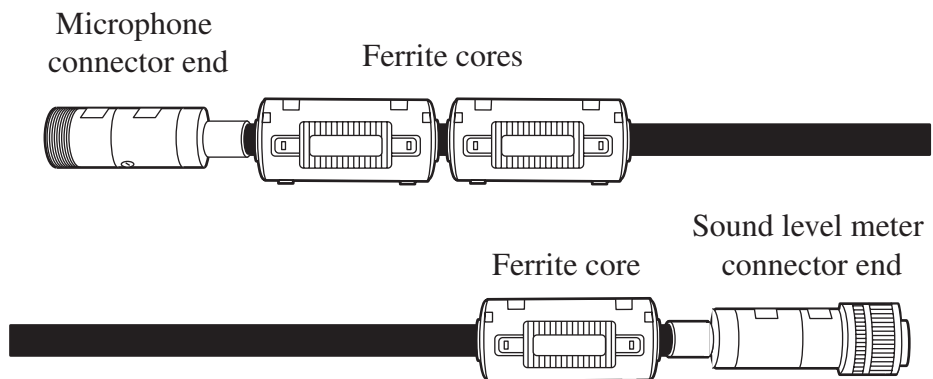

3. Pass the lower part of the insulation attachment onto the flange section of the MS-11.

The insulation attachment is not yet fixed at this point.

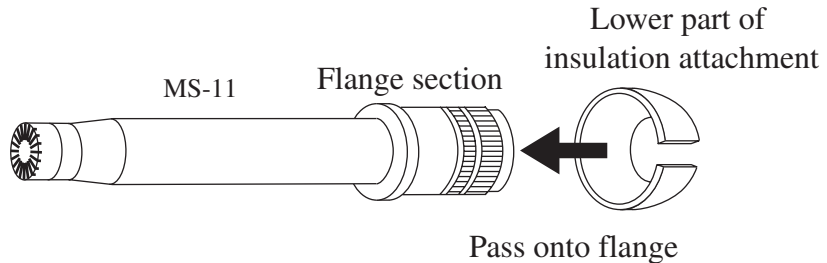

4. Connect the microphone extension cable to the MS-11. Rotate the outer part of the connector until the cable connector and the MS-11 are firmly joined by the screw thread.

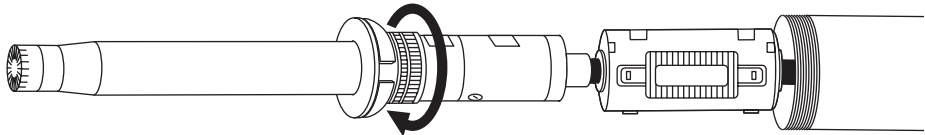

(Fastening to mounting tube)

5. Insert the microphone into the mounting tube from the top. The inside of the mounting tube has a ridge that is designed to prevent the microphone from turning. The ridge must be aligned with the cutout on the lower part of the insulation attachment.

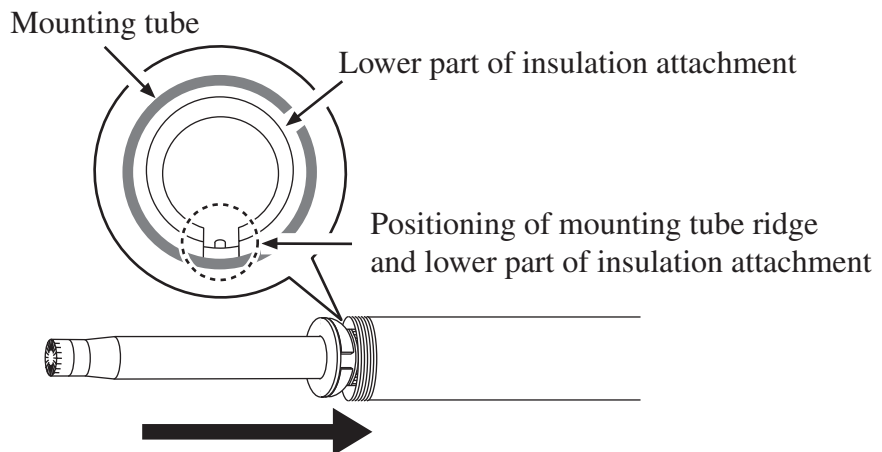

(Attaching the windscreen)

(If windscreen and inner cap are to be reattached after replacing these parts, perform steps 7 to 9.)

6. The windscreen is shipped from the factory with the base and inner cap attached. Insert the MS-11 directly into the assembly and rotate the base to attach it to the mounting tube.

Note
To remove the base and windscreen for maintenance, rotate the base section in the opposite direction than during installation. This lets you remove the base and windscreen together.
To remove the windscreen only, pull out the three spring hooks that are holding the windscreen.

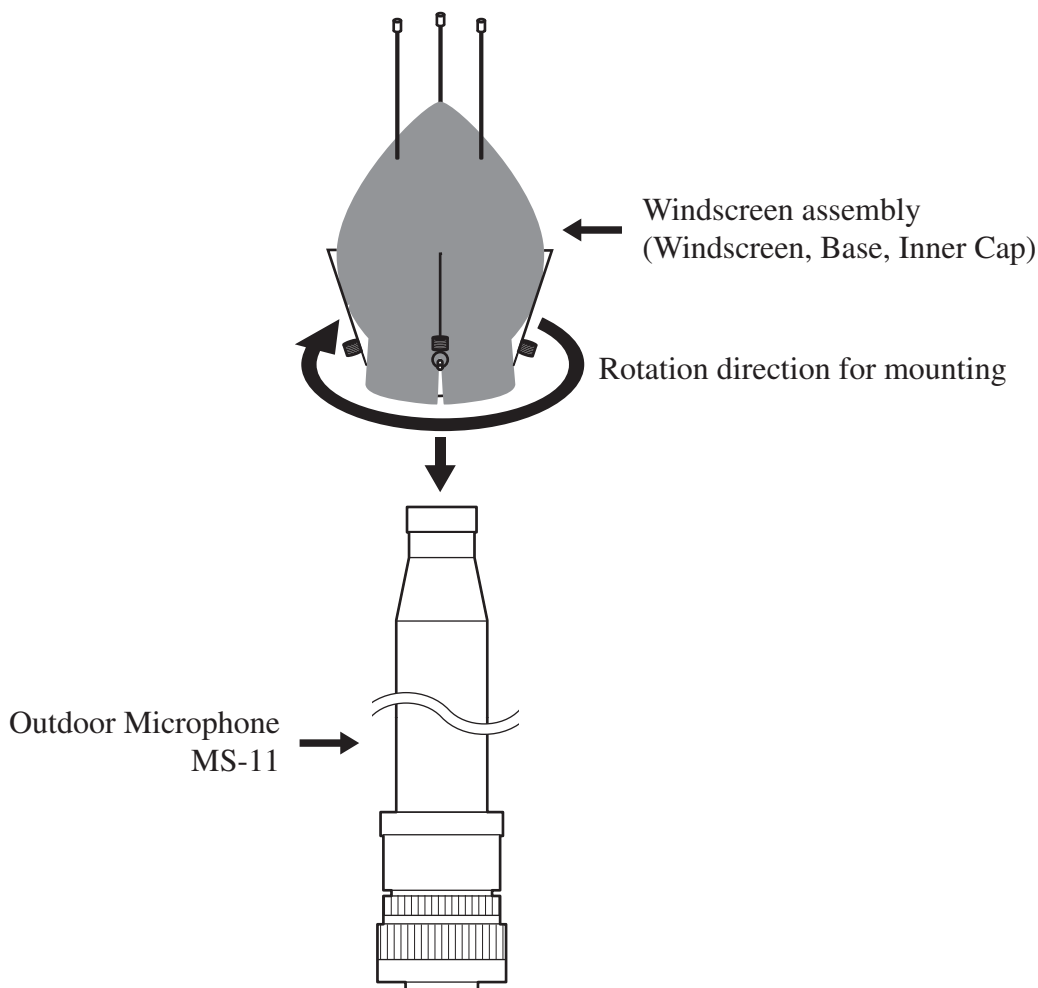

(Procedure after replacing the inner cap)

7. Insert the microphone into the base and rotate the base to securely fasten it to the mounting tube.

While doing this, take care that the tips of the springs attached to the base do not come into contact with the MS-11 microphone.

Next, attach the windscreen (steps 8 to 9).

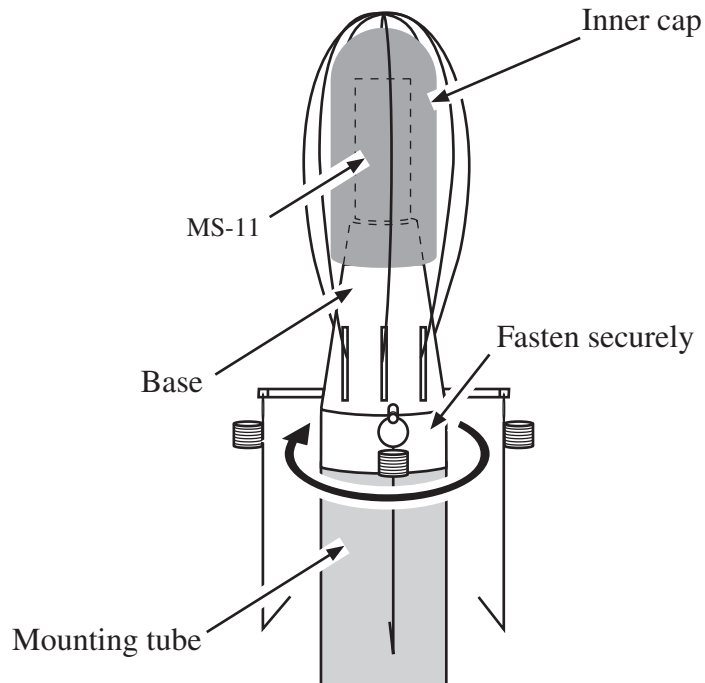

### Important

When reconnecting after replacing the inner cap, trying to attach the windscreen to the base while the microphone is removed may cause the inner cap to shift, so that the microphone will later not properly fit into the hole of the inner cap.

When the windscreen and base were removed as a unit, they can also be reattached as a unit.



(Mounting the windscreen)

8. In the lower part of the windscreen, there are three slits. Align these slits with the hooks on the base and push the windscreen fully onto the base.

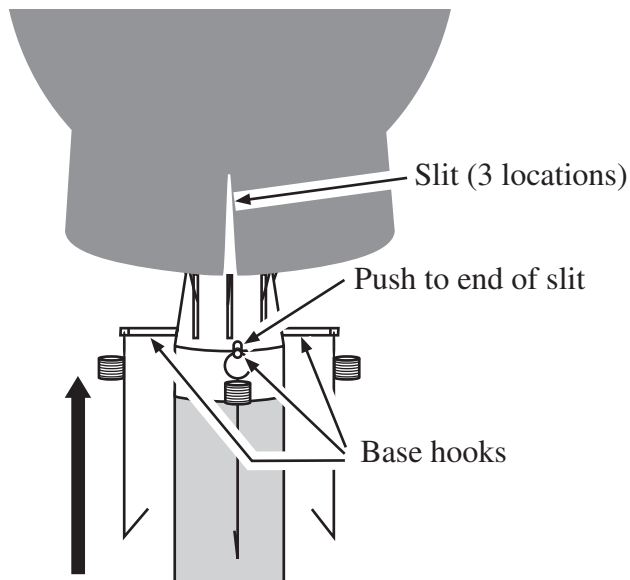

9. Push the tips of the springs attached to the hooks firmly into the windscreen, at about the middle section.

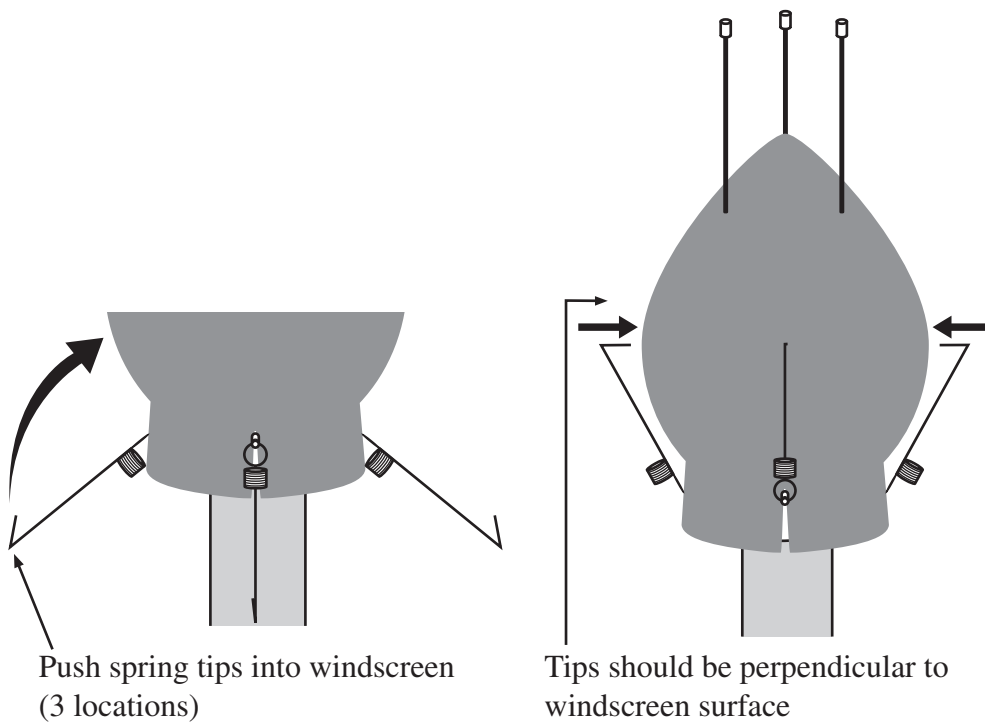

## Microphone connection

When using the All-Weather Windscreen WS-13, refer to the preceding “Using the All-Weather Windscreen WS-13” section for information on connecting the microphone and microphone extension cable.

<b>Important</b>
Disconnect the power before making any connections (see page 21).
Use only the microphone whose serial number is shown on the name plate of the unit.
The microphone also picks up vibrations. Ensure that the installed MS-11 and other equipment does not vibrate due to wind or other causes.
The Microphone Extension Cable EC-04 series is a separate option. Select the required length for your installation. For IEC compliance, the maximum cable length is 35 meters. For CE marking compliance, the maximum cable length is 30 meters.

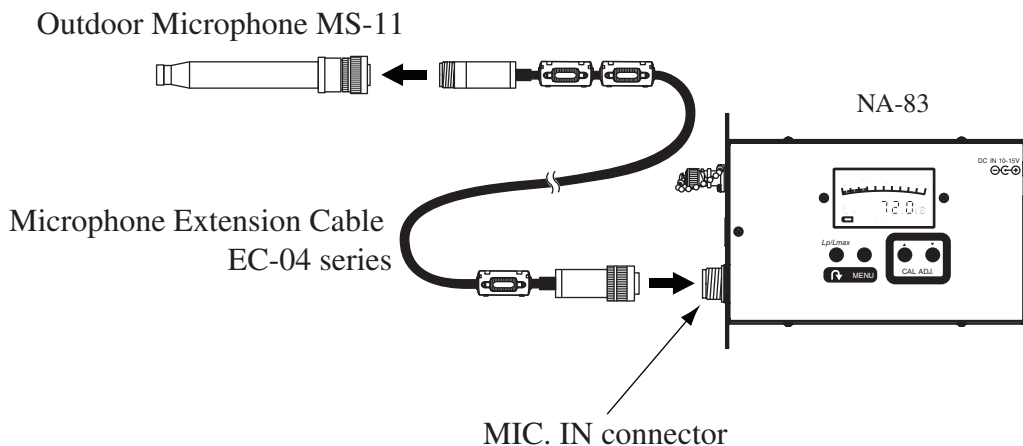

1. Attach the three supplied ferrite cores to the microphone extension cable (see page 11).
2. Connect the Outdoor Microphone MS-11 and Microphone Extension Cable EC-04 series.
3. Plug the extension cable into the MIC. IN connector.

## Mounting the All-Weather Windscreen WS-13 on a tripod

The All-Weather Windscreen WS-13 attached to the microphone can be mounted to the optional All-Weather Windscreen Tripod ST-81 or ST-88.

### Mounting on All-Weather Windscreen Tripod ST-81

Connect the adapter of the WS-13 mounting tube and the tip of the ST-81, as shown below.

When finished, verify that the connection is firm and without play.

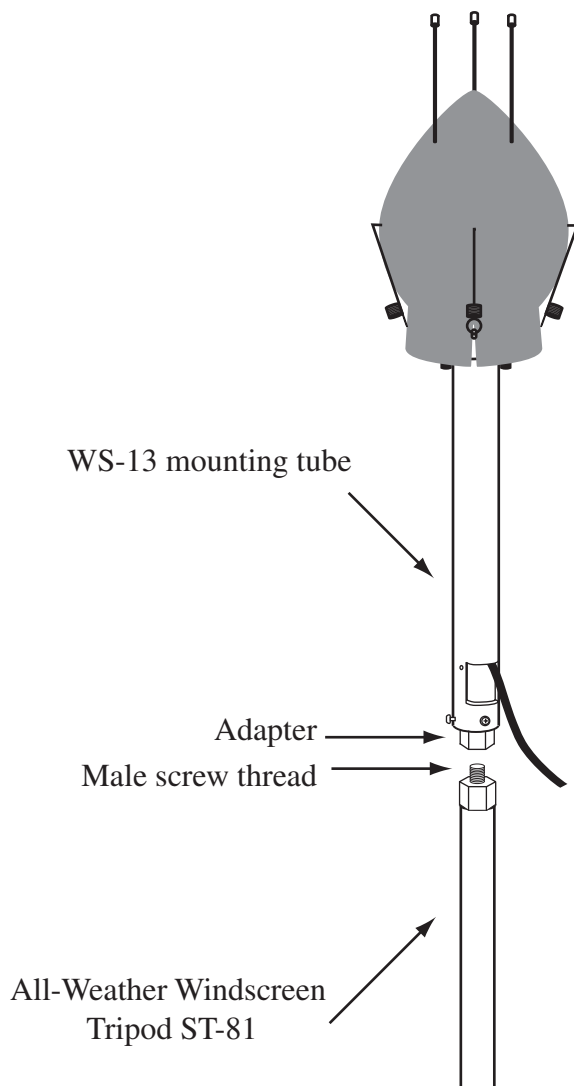

Note
When mounting to the ST-81, the screw hole next to the cable cutout on the mounting tube is not used.

## Mounting on All-Weather Windscreen Tripod ST-88

1. Loosen the three screws at the bottom of the WS-13 mounting tube and remove the adapter.

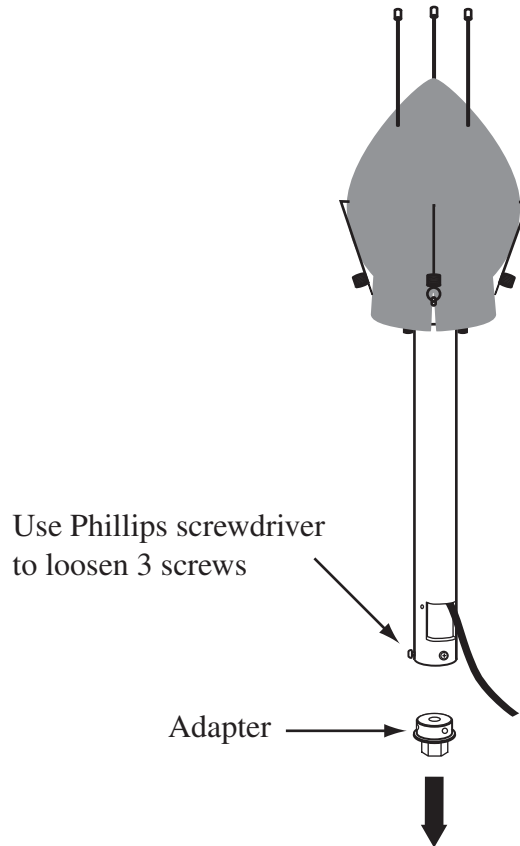

2. Push the WS-13 mounting tube into the tip of the ST-88.

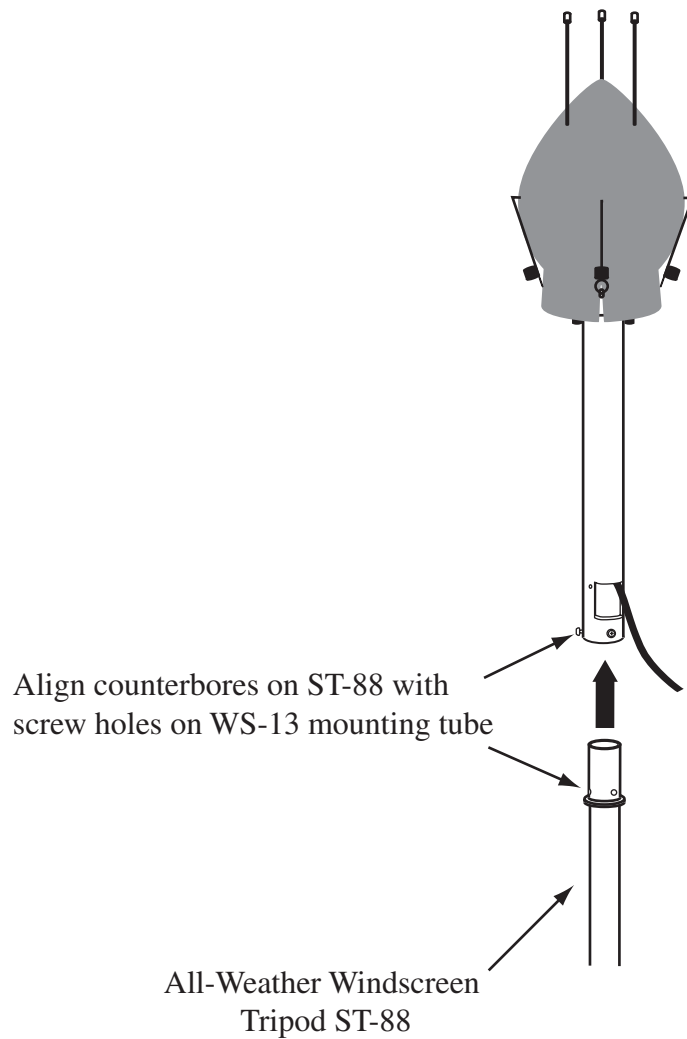

3. Tighten the three screws on the WS-13 mounting tube.  
When finished, verify that the connection is firm and without play.

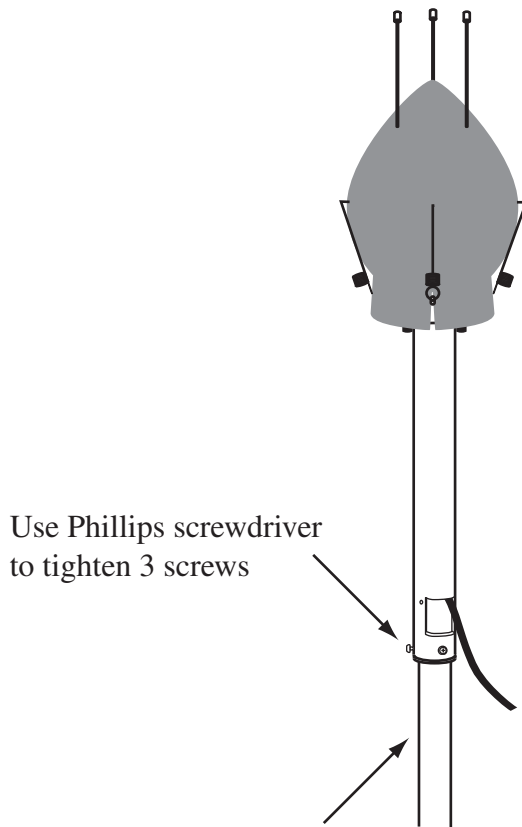

All-Weather Windscreen  
Tripod ST-88

Note
When mounting to the ST-88, the screw hole next to the cable cutout on the mounting tube is not used.

## Power on/off switching (AC adapter connection)

Power on/off to the NA-83 is controlled by connecting the AC adapter.

The allowable power supply voltage range is 10 to 15 V DC.

Use the specified AC adapter (RC45-12L, option).

Use six ferrite cores (option) together with the AC adapter, and wrap the cable once around each core, as shown below.

\* Ferrite core FCA8K ×6 (option)

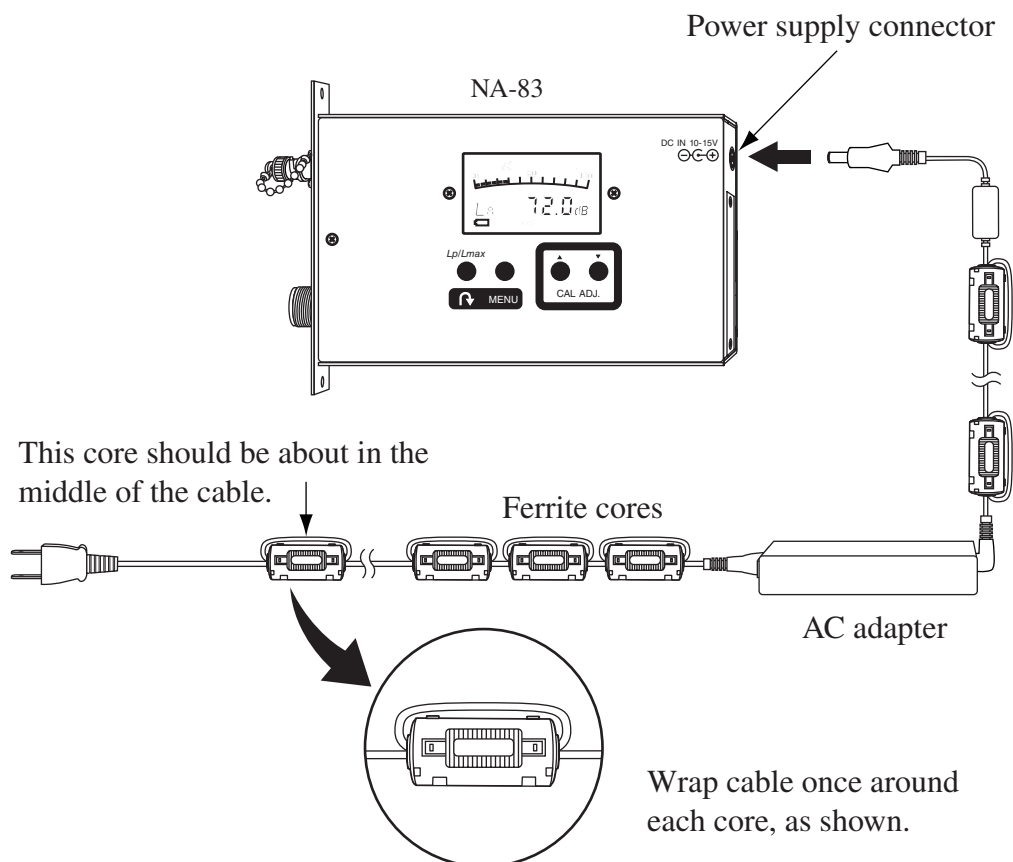

### Power on

1. Plug the cable from the AC adapter into the power connector on the NA-83.
2. Connect the AC adapter to an AC outlet (100 to 240 V AC, 50/60 Hz).

### Power off

Carefully pull the plug of the AC adapter out of the power connector on the NA-83.

## Connection of AC/DC OUT connector

The AC/DC OUT connector of the NA-83 is a BNC type connector which can be used to supply a signal to other equipment such as a level recorder or signal analyzer. Use a cable with BNC plug for the connection, and mount one ferrite core (option) on the cable.

- \* BNC-BNC cable NC-39A      1.5 m (option)
- \* Ferrite core FCA8K          ×1 (option)

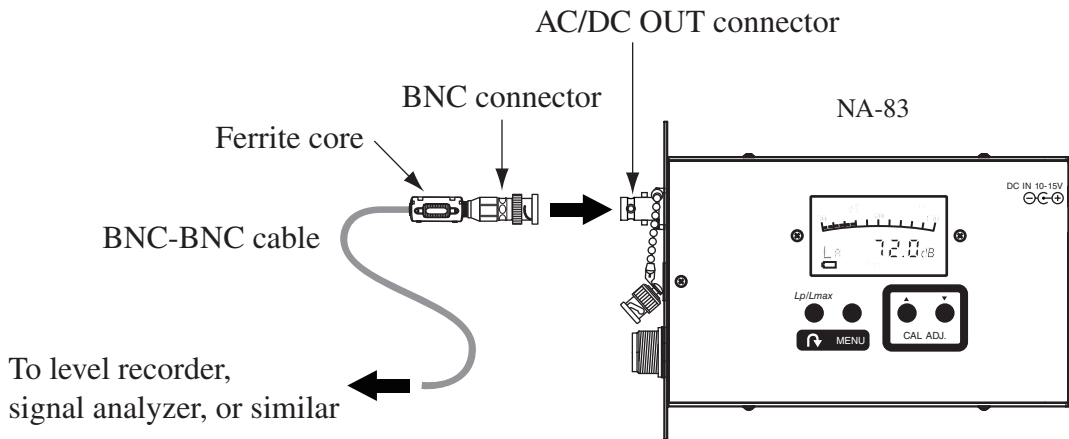



# Menu Setup

## Microphone integrated sound source setup

You can turn the microphone integrated sound source on or off as described below.

Normally, the ON setting is used. This is also the default setting when power is supplied to the NA-83.

**ON:** The sound source integrated in the MS-11 can be used, for acoustic calibration including the microphone and NA-83.

**OFF:** The internal test signal generator (1 kHz, sinusoidal wave) of the NA-83 is used, for electrical calibration of the NA-83 only.

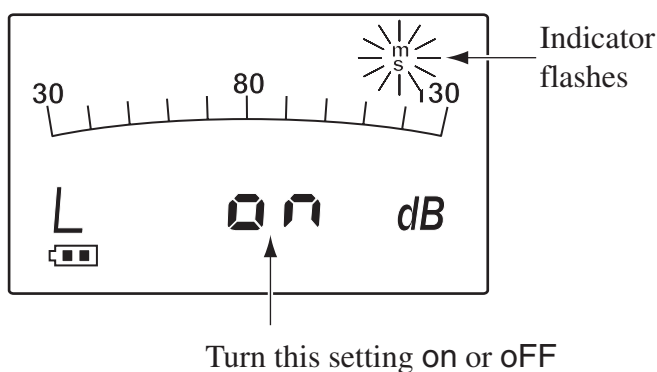

### Microphone integrated sound source setup screen

1. From the normal measurement screen, press the MENU key seven times to bring up the microphone integrated sound source setup screen. The indicator (ms) on the upper right of the screen flashes.
2. Use the  $L_p/L_{max}$  key to select the microphone integrated sound source setting.
  - “on”: Microphone integrated sound source ON
  - “oFF”: Microphone integrated sound source OFF
3. Press the MENU key or a CAL ADJ. key to return to the measurement screen.

## Frequency weighting setup

For regular sound level measurement, “A” weighting is normally used.

When “C” weighting is selected, sound pressure level is measured with flat response in the range from 31.5 Hz to 8 kHz.

When “Z” weighting is selected, sound pressure level is measured with flat response in the range from 20 Hz to 20 kHz.

For compliance with specifications and legal requirements, select the appropriate frequency weighting setting.

The default setting when power is supplied to the NA-83 is “A” weighting.

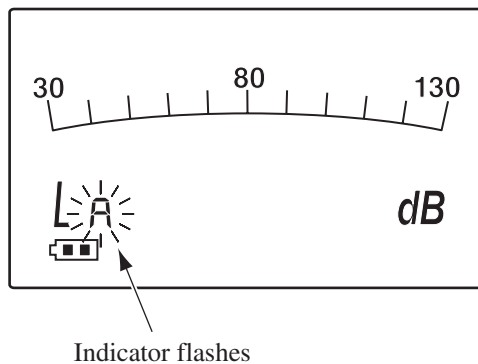

Frequency weighting setup screen

1. From the normal measurement screen, press the MENU key once to bring up the frequency weighting setup screen.
2. Use the  $L_p/L_{\max}$  key to select the frequency weighting setting.
  - “A”: A weighting
  - “C”: C weighting
  - “p”: Z weighting
3. Press the MENU key seven times to return to the measurement screen.  
(The CAL ADJ. keys can also be used.)

## Time weighting setup

For compliance with specifications and legal requirements, select the appropriate time weighting setting.

The default setting when power is supplied to the NA-83 is time weighting F (Fast).

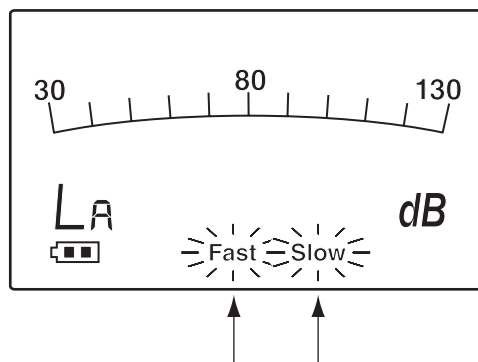

One of these indicators flashes,  
showing the selected setting

### Time weighting setup screen

1. From the normal measurement screen, press the MENU key twice to bring up the time weighting setup screen.
2. Use the  $L_p/L_{max}$  key to select the time weighting setting.
  - “Fast”: Time weighting F (Fast)
  - “Slow”: Time weighting S (Slow)
3. Press the MENU key six times to return to the measurement screen. (The CAL ADJ. keys can also be used.)

## AC/DC OUT setup

Lets you select the signal to be supplied from the AC/DC OUT connector.

### AC OUT

An AC signal derived from the measurement data using C weighting is output.

An output level of 1.0 Vrms corresponds to sound level of 110 dB.

Example:

When the sound level is 90 dB,  $90 \text{ dB} = 110 \text{ dB} - 20 \text{ dB}$ , therefore the output voltage is 0.1 Vrms.

### DC OUT

A DC signal using logarithmic compression and based on the currently selected frequency weighting and time weighting settings is output.

An output level of 5.5 V corresponds to sound level of 130 dB.

The signal voltage drops by 0.05 V per dB.

Example:

When the sound level is 120 dB, the output level is calculated as:  
 $5.5 - 0.05 \times (130 - 120) = 5.0 \text{ (V)}$ .

The default setting when power is supplied to the NA-83 is DC OUT.

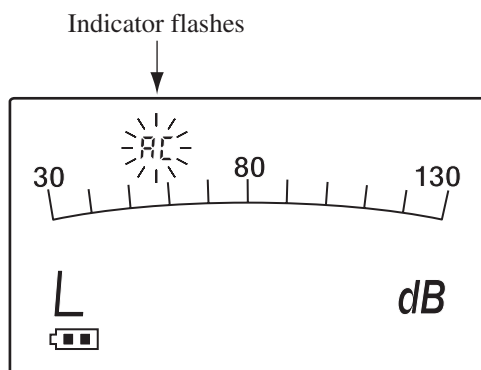

AC/DC OUT setup screen

1. From the normal measurement screen, press the MENU key five times to bring up the AC/DC OUT setup screen.
2. Use the  $L_p/L_{max}$  key to select the AC/DC OUT setting.
  - “AC”: AC output
  - “dC”: DC output
3. Press the MENU key three times to return to the measurement screen. (The CAL ADJ. keys can also be used.)

## Windscreen correction setup screen

When the All-Weather Windscreen WS-13 is mounted on the Outdoor Microphone MS-11, frequency response will change due to the influence of the windscreen. Windscreen correction uses digital processing to correct for this change and ensure compliance with the Measurement Law requirements for precision sound level meters, IEC 61672-1:2002 Class 1 (JIS C 1509-1:2005 Class 1).

The default setting when power is supplied to the NA-83 is no windscreen correction.

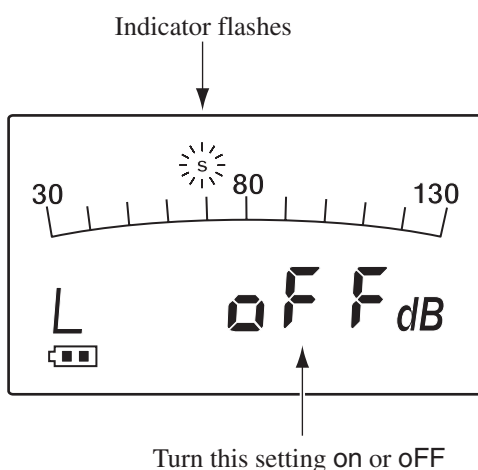

Windscreen correction setup screen

1. From the normal measurement screen, press the MENU key six times to bring up the windscreen correction setup screen.
2. Use the  $L_p/L_{max}$  key to select the windscreen correction setting.
  - “on”: Windscreen correction ON
  - “oFF”: Windscreen correction OFF
3. Press the MENU key twice to return to the measurement screen. (The CAL ADJ. keys can also be used.)

### Important

The AC OUT signal does not reflect the windscreen correction setting.

# Calibration and Operation Check

## Calibration with microphone integrated sound source

The integrated sound source of the Outdoor Microphone MS-11 can be used for acoustic calibration. The test tone is a 1 kHz sinusoidal wave signal, and the calibration level is 114.0 dB. Use the CAL ADJ. keys to adjust the calibration level.

Important
The microphone has an integrated heater to prevent internal condensation. Before starting calibration, the microphone should have been powered for at least 5 to 10 minutes, to allow the heater to warm up.
The sensitivity of the integrated sound source differs for individual microphones. Sensitivity adjustment is therefore performed at the factory for each microphone individually, in conjunction with the respective NA-83. Verify that the serial number of the microphone matches the number shown on the name plate of the NA-83 unit.
The microphone also picks up vibrations. Ensure that the installed MS-11 does not vibrate due to wind or other causes.

Verify that indicator is shown constantly (not flashing)

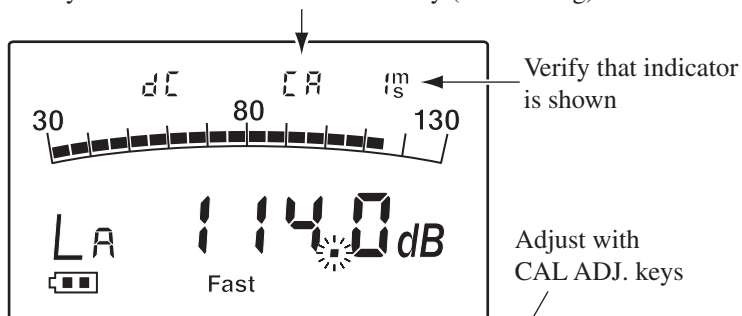

Lp/Lmax

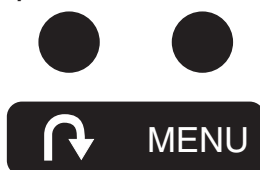

1. Set the frequency weighting to “A” (page 24).
2. Verify that the MS-11 indicator (ms) is shown. If not, set the microphone integrated sound source to ON from the MENU screen (page 23).
3. From the normal measurement screen, press the MENU key three times to bring up the screen for calibration and operation check with microphone integrated sound source. Make sure that the calibration indicator (CA) is shown constantly, not flashing.
4. Use the  $L_p/L_{\max}$  key to select the integrated sound source indication “CA 1” (1 kHz).
5. Use the CAL ADJ. keys to bring the indication on the numeric readout to “114.0 dB”.
6. Press the MENU key five times to return to the normal measurement screen. This completes the calibration procedure.

### Atmospheric pressure correction

The output sound pressure of the integrated sound source fluctuates slightly depending on atmospheric pressure.

When pressure is low, the output will be slightly lower, and when pressure is high, the output will be slightly higher. If the atmospheric pressure can be verified, adjust the calibration as follows.

Atmospheric pressure (kPa)	Sound pressure level (dB)
91.7 to 93.8	113.6
93.9 to 95.9	113.7
96.0 to 97.9	113.8
98.0 to 100.1	113.9
100.2 to 102.3	114.0
102.4 to 104.7	114.1

## Acoustic calibration with Sound Calibrator NC-74

This section describes how to perform acoustic calibration with the Sound Calibrator NC-74 attached to the Outdoor Microphone MS-11. The test tone is a 1 kHz sinusoidal wave signal, and the calibration level is 94.0 dB. Use the CAL ADJ. keys to adjust the calibration level.

<b>Important</b>
<p>The microphone has an integrated heater to prevent internal condensation. Before starting calibration, the microphone should have been powered for at least 5 to 10 minutes, to allow the heater to warm up.</p>
<p>Proceed very carefully and slowly when mounting the Sound Calibrator NC-74 on the microphone. Pushing the calibrator in or removing it too fast causes a rapid change in the pressure inside the coupler, which can cause fatal damage to the microphone diaphragm. For details on using the Sound Calibrator NC-74, refer to the documentation of that product.</p>

Verify that indicator is flashing (not shown constantly)

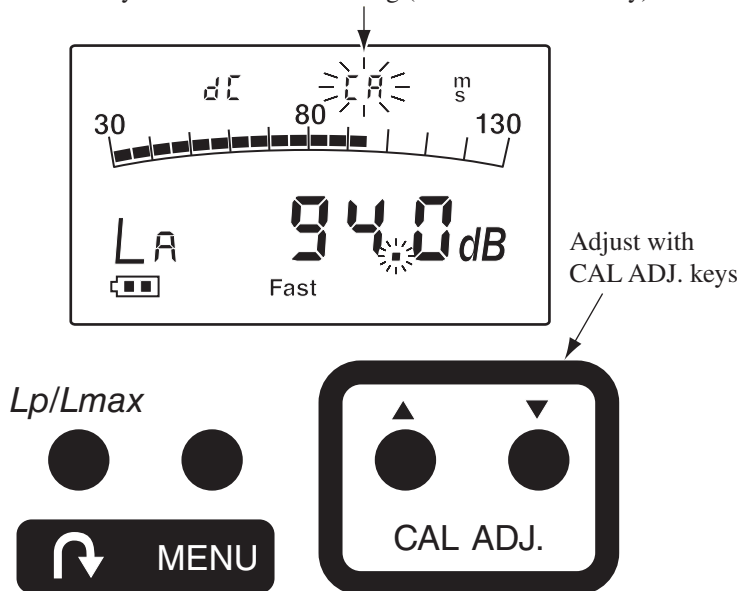



1. Turn power to the Sound Calibrator NC-74 off.
2. Set the frequency weighting to “A” (page 24).
3. From the normal measurement screen, press the MENU key four times to bring up the screen for calibration with an external sound calibrator. Make sure that the calibration indicator (CA) is flashing, not shown constantly.
4. Proceeding slowly and carefully, insert the Outdoor Microphone MS-11 all the way into the coupler of the Sound Calibrator NC-74, and turn the NC-74 on.
5. Use the CAL ADJ. keys to bring the indication on the numeric readout to “94.0 dB”.
6. Press the MENU key four times to return to the normal measurement screen. This completes the calibration procedure.
7. Turn power to the Sound Calibrator NC-74 off, and slowly and carefully remove the microphone from the coupler.

## Operation check with microphone integrated sound source

Using the integrated sound source of the Outdoor Microphone MS-11, perform an operation check as follows. The sound source frequencies for operation check are 250 Hz, 500 Hz, and 4 kHz (sinusoidal wave signals).

<b>Important</b>
The 250 Hz, 500 Hz, and 4 kHz sound source frequencies are for operation checking only. Do not use the CAL ADJ. keys for adjustment in this mode.
The information about atmospheric pressure given in the section “Atmospheric pressure correction” on page 29 applies also to operation check.

Verify that indicator is shown constantly (not flashing)

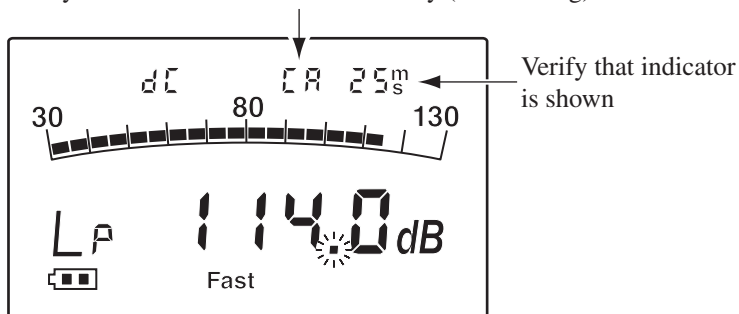

1. Set the frequency weighting to “Z” (indication “p”) (page 24).
2. Verify that the MS-11 indicator (ms) is shown. If not, set the microphone integrated sound source to ON from the MENU screen (page 23).
3. From the normal measurement screen, press the MENU key three times to bring up the screen for calibration and operation check with microphone integrated sound source. Make sure that the calibration indicator (CA) is shown constantly, not flashing.
4. Use the  $L_p/L_{max}$  key to select the frequency for the integrated sound source.  
CA 25: 250 Hz   CA 50: 500 Hz   CA 4: 4 kHz  
(The 1 kHz frequency is for calibration.)
5. Press the MENU key five times to return to the normal measurement screen.

# Measurement

## Measurement of time-weighted sound level $L_p$ (instantaneous value)

The following explanation assumes that the steps for menu setup and calibration/operation check as explained in the preceding sections have been completed.

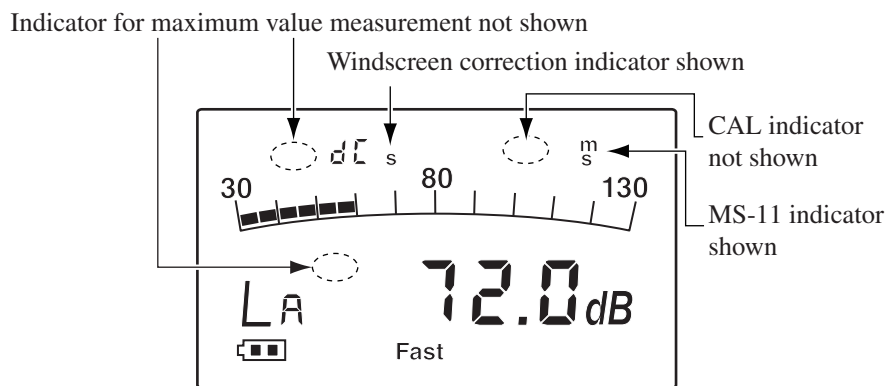

Measurement screen

1. Verify that the measurement screen is shown (no menu setup items, no CAL indication).
2. Verify that the indicator for maximum value measurement is not shown.

If the indicator is shown, press the  $L_p/L_{max}$  key to turn it off.

If the measurement screen is being shown and the maximum value measurement indicator is not visible, measurement for instantaneous value has started.

3. Verify that the MS-11 indicator (ms) is shown.
4. Check the indication for windscreen correction. If using the All-Weather Windscreen WS-13, the setting should be ON.

5. Check the frequency weighting indication.

To measure sound level normally, frequency weighting should be set to “A”.

To measure C-weighted or Z-weighted sound level, frequency weighting should be set to “C” or “Z”.

To change the setting, use the frequency weighting setup screen (page 24).

6. Check the time weighting indication.

“Fast”: Time weighting F (Fast)

“Slow”: Time weighting S (Slow)

To change the setting, use the time weighting setup screen (page 25).

## Measurement of maximum time-weighted sound level $L_{\max}$

The following explanation assumes that the steps for menu setup and calibration/operation check as explained in the preceding sections have been completed.

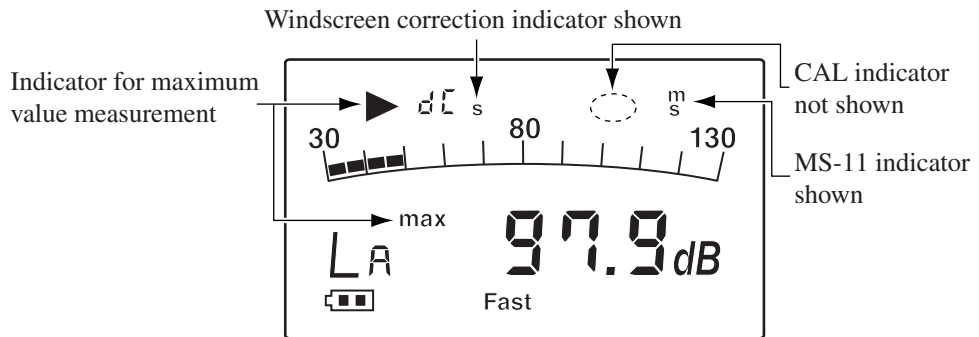

Measurement screen

1. Verify that the measurement screen is shown (no menu setup items, no CAL indication).
2. Verify that the indicator for maximum value measurement is not shown.  
If the indicator is shown, press the  $L_p/L_{\max}$  key to turn it off. This will reset the maximum value.
3. Verify that the MS-11 indicator (ms) is shown.
4. Check the indication for windscreen correction. If using the All-Weather Windscreen WS-13, the setting should be ON.
5. Check the frequency weighting indication.

To measure sound level normally, frequency weighting should be set to "A".

To measure C-weighted or Z-weighted sound level, frequency weighting should be set to "C" or "Z".

To change the setting, use the frequency weighting setup screen (page 24).

6. Check the time weighting indication.  
“Fast”: Time weighting F (Fast)  
“Slow”: Time weighting S (Slow)  
To change the setting, use the time weighting setup screen (page 25).
7. Use the  $L_p/L_{\max}$  key to turn on the maximum value measurement indicator. When “max” is shown on the display, maximum value measurement has started and the numeric readout is switched to show the maximum value.
8. To terminate maximum value measurement, press the  $L_p/L_{\max}$  key again. The maximum value measurement indicator goes out, and the numeric readout is switched back to show the instantaneous value.

# Connectors

## MIC. IN connector

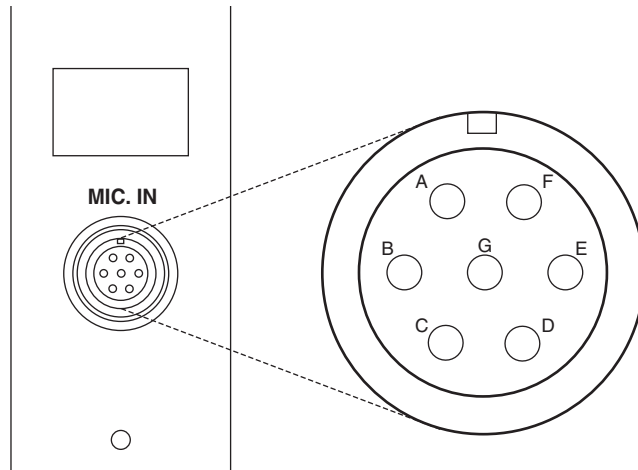

- A: +15 V (preamplifier power supply)
- B: Ground
- C: Microphone signal input
- D: -15 V (preamplifier power supply)
- E: Calibration signal output
- F: Heater power supply (+)
- G: Heater power supply (-) (Ground)

The heater current for the MS-11 flows from F to G (approx. 100 mA).

### Important

The MS-11 has connector pins for the integrated heater and integrated sound source. Do not connect the MS-11 to a sound level meter other than the NA-83. In particular, sound level meters that provide a bias voltage through the microphone connector may damage the MS-11.

## Rear-panel connector

The rear-panel connector becomes accessible when the cover plate is removed. Plug in the supplied communication connector (KEL 8300-032-281), and use the pinout information given below to supply power to the NA-83 and perform serial communication for operation control and measurement data retrieval.

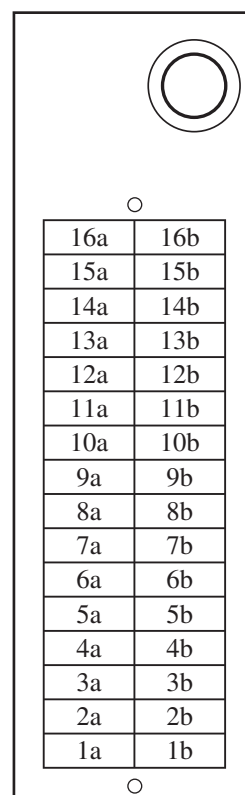

Pin assignment		Pin designation	Explanation
16a	16b	GND	Ground terminals for power supply and RS-232C communication.
15a	15b		
14a	14b		
13a	13b	Power	Power supply voltage range: 10 to 15 V DC Current consumption: approx. 200 mA (12 V DC)
12a	12b		
11a	11b		
10a	10b	Not used	
9a	9b		
8a	8b	$\overline{\text{RESET}}$	Hardware reset input (L: trigger reset)
7a	7b	TxD	RS-232C communication, send data
6a	6b	RxD	RS-232C communication, receive data
5a	5b	Prohibited	Do not connect to other equipment.
4a	4b		
3a	3b		
2a	2b		
1a	1b		



# Wiring diagram

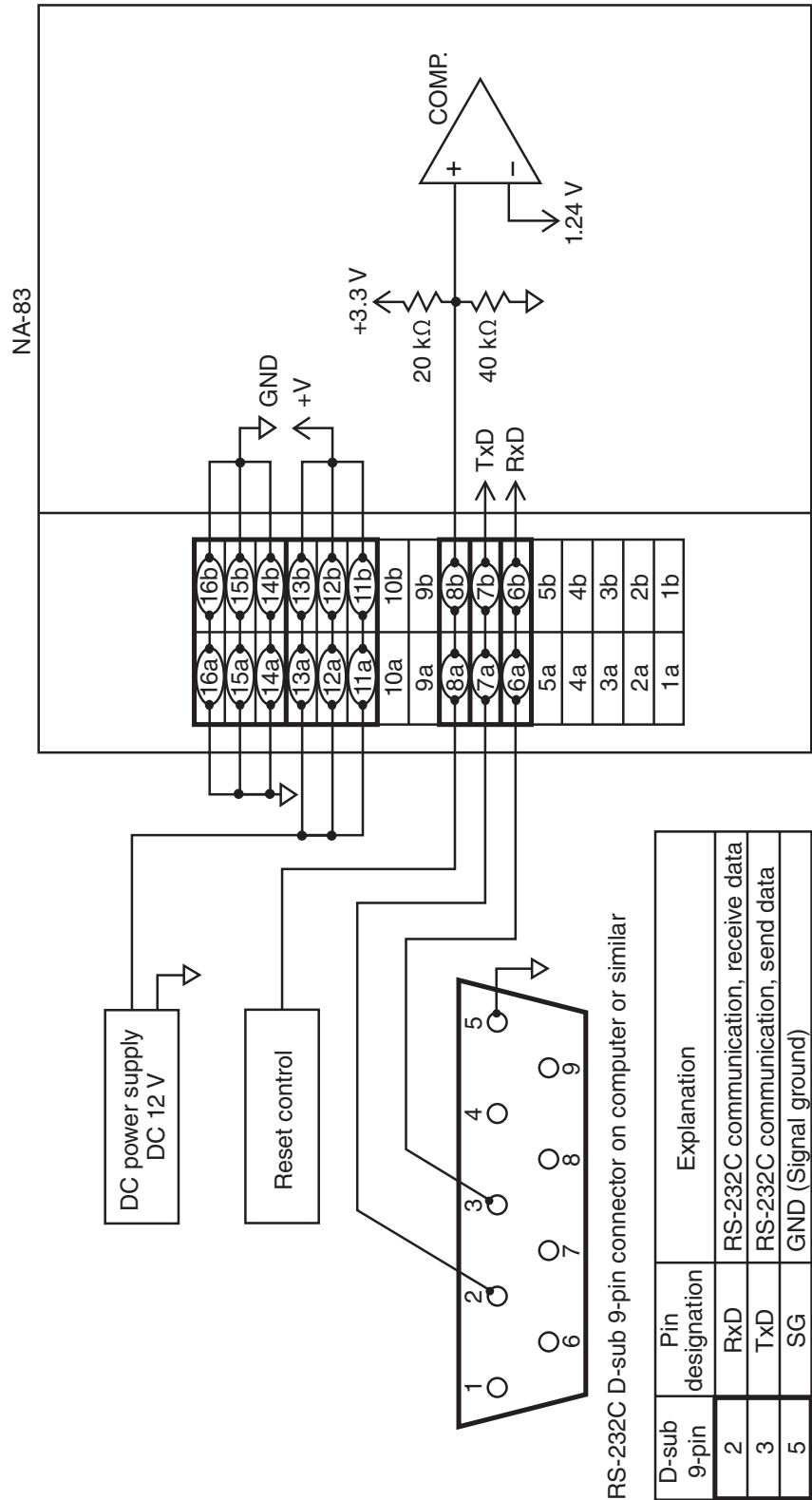

## DC power supply

Supply a 12 V source to these pins. To handle the in-rush current at power-on, the output current rating of the power supply should be at least 1 A.

Important
When supplying power via the rear-panel connector, do not use the power supply connector at the same time, because this can lead to damage.
Make sure that the specifications of the power supply meet the requirements and that voltage is stable and electrical noise is low. High levels of electrical noise or voltage fluctuations can lead to damage.

## Reset control

Performing a reset reestablishes the same default settings as at power-on (see page 41). A reset is triggered when the reset signal falls below the internal comparator voltage (1.24 V) of the NA-83. If reset does not need to be performed, either leave the pins open or pull up the voltage to +3.3 V with a 50 k $\Omega$  resistor.

# Default Values

Each time when power to the NA-83 is supplied, the following settings are established. (The unit does not have a resume function.)

- Numeric readout  
Time-weighted sound level  $L_p$  (instantaneous value)
- Frequency weighting A
- Time weighting F (Fast)
- Microphone integrated sound source ON
- Frequency of microphone integrated sound source 1 kHz
- AC/DC OUT setting DC OUT
- Windscreen correction setting OFF

# Technical Reference

## Microphone and Preamplifier

The Sound Level Meter NA-83 uses the MS-11 which incorporates a small and highly stable electret condenser microphone with a heater, internal sound source, and preamplifier. The MS-11 is suitable for long-term outdoor measurement of sound levels. The integrated sound source makes regular maintenance and calibration easy. For details, see the section “Outdoor Microphone MS-11” on page 10.

The general microphone construction and operation principles as well as preamplifier requirements are explained below.

### Construction and Operation Principle

As shown in the illustration below, an electret condenser microphone normally consists of five main parts, namely the diaphragm, film, backplate, insulator, and case. A film with an electrical charge is normally mounted to the backplate. When sound pressure is applied to the diaphragm, the distance between the diaphragm and the backplate changes, thereby altering the capacitance. Using a load resistor, this change can be turned into a voltage change. The frequency response as well as the temperature and humidity characteristics of an prepolarized condenser microphone depend considerably on the type and properties of the materials used. The high frequency range is determined by the resonance frequency of the diaphragm assembly.

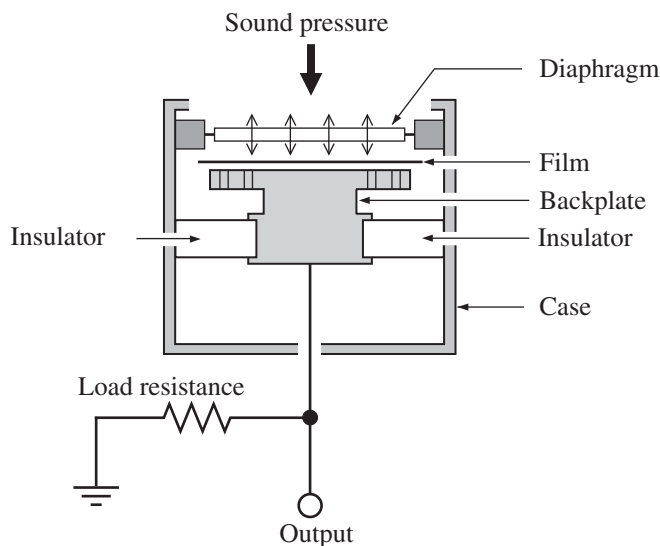

Construction of prepolarized condenser microphone

## Thermal Characteristics

The thermal characteristics of a microphone indicate how sensitivity changes at various temperatures. This is influenced by the choice of materials and the design of the microphone. Normally, materials with a linear expansion coefficient are used. The diagrams below show the thermal characteristics of the microphone MS-11.

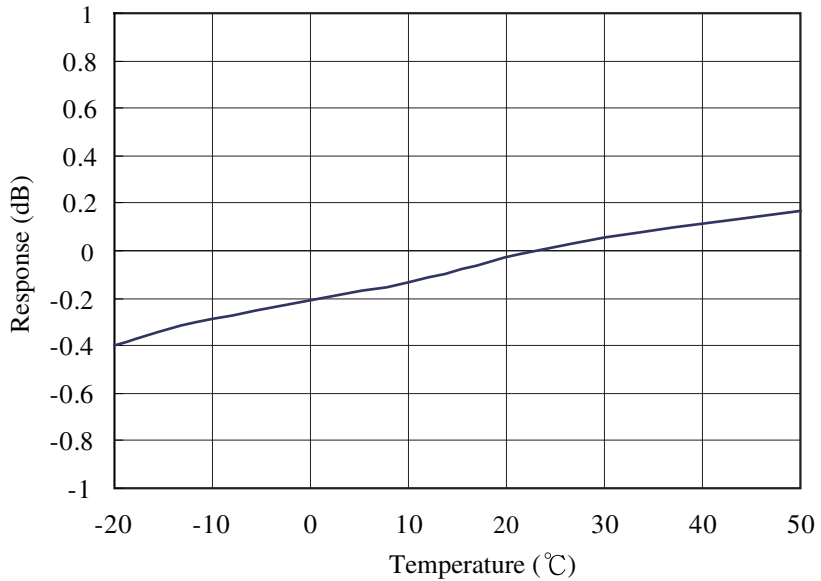

Thermal characteristics (at 250 Hz), reference temperature 23°C

## Humidity Characteristics

The humidity characteristics of a microphone indicate how sensitivity changes at various humidity levels. The diagrams below show the microphone MS-11.

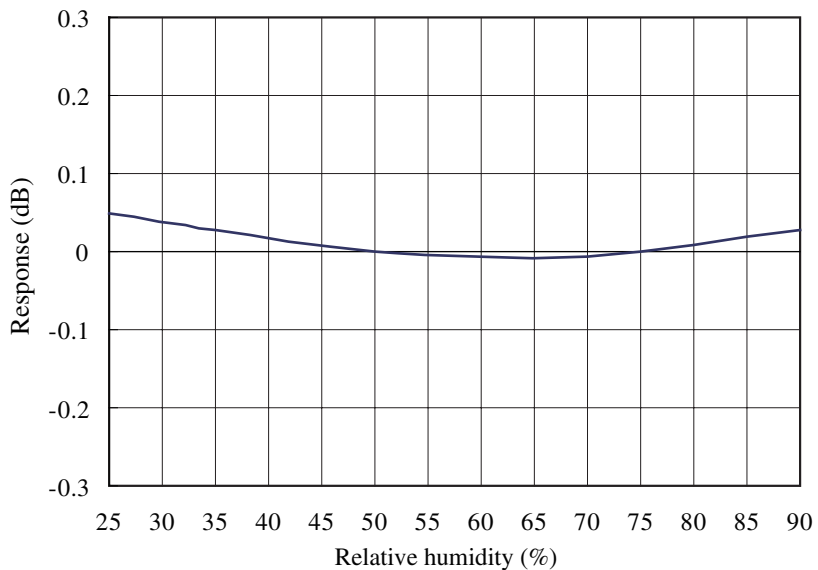

Humidity characteristics (at 250 Hz), reference relative humidity 50%

## Preamplifier

Since the condenser microphone is a small-capacity transducer, it has high impedance, especially at low frequencies. Therefore a very high load resistance is required to ensure uniform response extending to the low frequency range. The relationship between the microphone capacitance and the low-range cutoff frequency can be expressed as follows.

$$f_0 = \frac{1}{2\pi \times Z_{in} \times C_m}$$

$f_0$ : Low-range cutoff frequency (Hz)

$Z_{in}$ : Preamplifier input impedance ( $\Omega$ )

$C_m$ : Capacitance of condenser microphone (F)

If the output of the microphone were directly routed through a long shielded cable, the capacitance between the cable conductors would cause a sharp drop in sensitivity, as is evident from the following equation.

$$M_0 = \frac{C_m}{C_m + C_c} \cdot M_s$$

$M_0$ : Output voltage into directly connected shielded cable (V)

$M_s$ : Output voltage in microphone open condition (V)

$C_c$ : Cable capacitance of shielded cable (F)

For the above reasons, a preamplifier is connected directly after the microphone, to provide a low-impedance output signal.

## Integrated sound source

The sound source integrated in the microphone is a balanced armature type magnetic transducer which creates a sound pressure in the microphone rear chamber. The four sinusoidal wave signal tones generated by this source (250 Hz, 500 Hz, 1 kHz, 4 kHz) are used for calibration and for operation checking of the microphone.

## Condensation-preventing heater

Because it is designed for outdoor use, the MS-11 incorporates a thermofoil heater. This ensures that the chassis and internal temperature are higher than the ambient temperature, which prevents the formation of condensation.

## Influence of Microphone Extension Cable

When the output of the microphone/preamplifier is routed through an extension cable, certain limitations regarding measurable sound pressure level and frequency range will apply. This is due to the influence of the cable capacitance. The longer the cable, the lower the measurable sound pressure level and the lower the frequency limit. The diagram below shows the relationship among cable length, measurable sound pressure level, and frequency.

Model	Length	Model	Length
EC-04	2 m	EC-04C	30 m (reel)+5 m (connection cable)
EC-04A	5 m	EC-04D	50 m (reel)+5 m (connection cable)
EC-04B	10 m	EC-04E	100 m (reel)+5 m (connection cable)

Extension cable EC-04 series

If for example a sound pressure level of 123 dB is to be measured up to 8 kHz, an extension cable length of up to 100 meters can be used

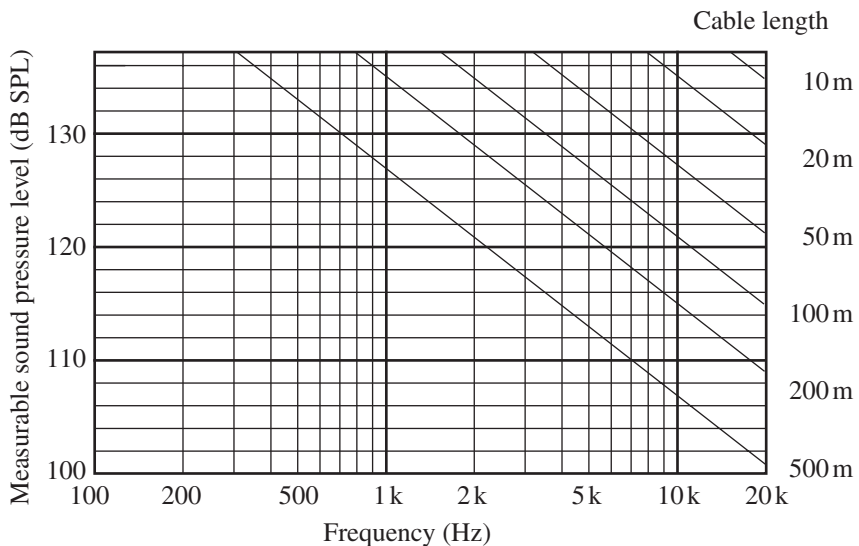

## Frequency Weighting Network

The NA-83 provides frequency weightings A, C and Z. The electrical characteristics of the frequency weighting network are as shown below.

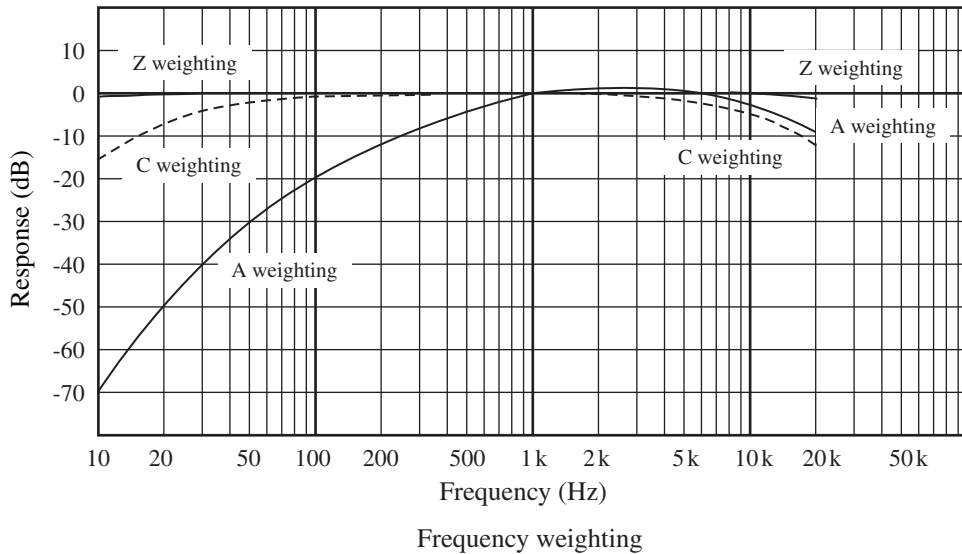

The volume impression (loudness) of a sound depends not only on the sound pressure level, but also on the frequency. At high or low frequencies, a sound is felt to be less loud than a sound of equal level in the midrange. The frequency weighting A compensates for this effect and produces measurement results which are close to the actual impression of loudness. For this reason, this type of frequency weighting is widely used for purposes such as sound level evaluation.

With the frequency weighting Z, frequency response is linear, which is suitable for sound pressure level measurements and for using the sound level meter output for frequency analysis.

The frequency weighting C curve produces almost flat response, but with a roll off below 31.5 Hz and above 8 kHz. This is suitable for sound pressure level measurements in situations with unwanted low-frequency or high-frequency components.



## RMS Detection Circuit and Time Weighting

The sound level meter uses rms detection. The effective value  $E$  (rms) is defined by the following equation.

$$E(\text{rms}) = \sqrt{\frac{1}{T} \int_0^T e^2 dt}$$

The voltage  $e$  which changes over time is raised to the second power, and integration for the time interval  $T$  is performed. The result is divided by  $T$  and the square root is extracted. The circuit configuration for performing the above mathematical operation looks as follows.

The NA-83 uses digital processing to determine the rms value.

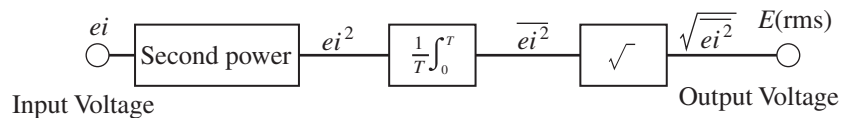

During sound level measurements, the level often fluctuates drastically, which would make it difficult to evaluate readings if some kind of averaging is not applied. Sound level meters therefore provide the capability for index weighting (index averaging) using the rms circuit. The parameters of this weighting process are called the time weightings, determined by the time constant (see next page).

Sound level meters usually have an F (Fast) and S (Slow) setting for the time weighting. The time range that is considered for averaging is narrow in the F setting and wide in the S setting. In the F setting, the instantaneous level has a larger bearing on the displayed value than in the S setting. From the point of view of the measurement objective, the F setting is more suitable to situations with swiftly changing sound level, whereas the S setting yields a more broadly averaged picture.

The F setting is more commonly used, and sound level values given without other indication are usually made with F characteristics.

The S setting is suitable for measuring the average of sound with fairly constant levels. For example, in Japan aircraft noise and high-speed train noise is usually transient noise with high fluctuation, but the S setting is used to determine the maximum level for each noise event.

Time weightings and time constant

Time weightings	Time constant	
	Rise time	Decay time
F (Fast)	125 ms	125 ms
S (Slow)	1 s	1 s

The time weighting network of the sound level meter performs index averaging on the square of the sound pressure signal. The equivalent circuit is shown below.  $\tau$  is the time constant, which equals  $CR$ .

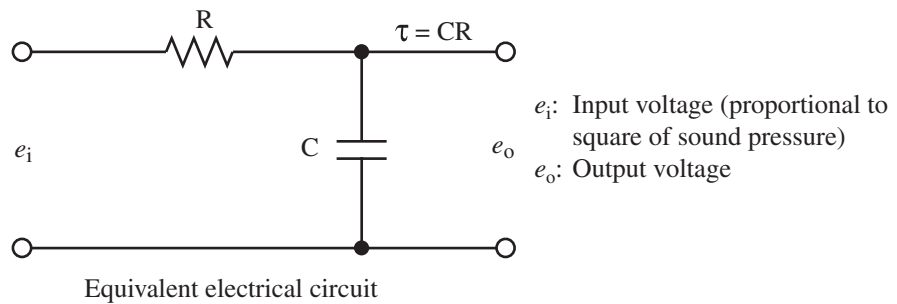

The response of the index averaging circuit to a single burst signal is shown below.

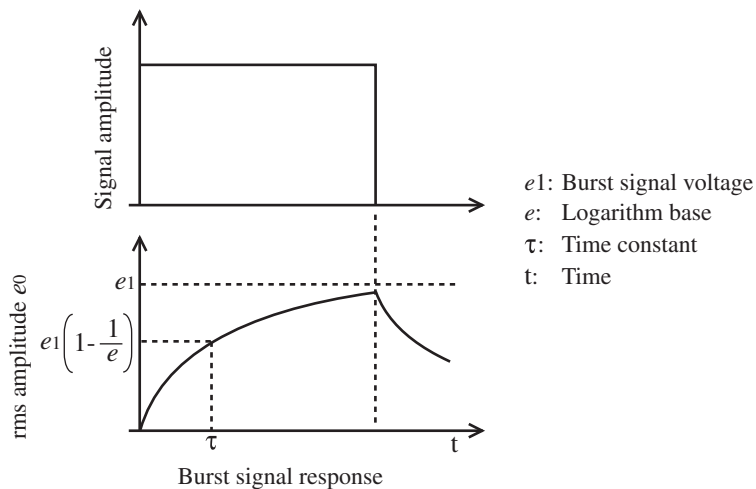

## Influence of Background Noise

When measuring a certain sound in a certain location, all other sounds present at that location except the measurement target sound are background noise. Since the sound level meter will display the combination of target sound and background noise, the amount of background noise must be taken into consideration when determining the level of the target sound.

If the difference between the meter reading in absence of the target sound and the reading with the target sound is more than 10 dB, the influence of background noise is small and may be disregarded. If the difference is less than 10 dB, the values shown in the table below may be used for correction, to estimate the level of the target sound.

Background noise correction

Display reading difference with and without target sound (dB)	4	5	6	7	8	9
Correction value (dB)	-2		-1			

If for example the measured sound level when operating a machine is 70 dB, and the background noise level when the machine is not operating is 63 dB, the correction value for the difference of 7 dB is -1 dB. Therefore the sound level of the machine can be taken to be  $70 \text{ dB} + (-1 \text{ dB}) = 69 \text{ dB}$ .

The above principle for correcting the influence of the background noise assumes that both the background noise and the target sound are approximately constant. If the background noise fluctuates, and especially if it is close in level to the target sound, correction is difficult and will often be meaningless.

## Description for IEC 61672-1

Standard paragraph	Description	See also	Remark
<b>5</b>	<b>Performance specifications</b>		
<b>5.1</b>	<b>General</b>		
5.1.4	Configuration & normal mode of operation	9.2.1 b)	Configuration • NA-83    • MS-11    • WS-13 • Microphone extension cable • AC adapter • Ferrite cores (→ Connections) Normal mode of operation → Connections Unit powered and windscreen correction set to ON
5.1.6	Models of microphone Appropriate procedures for use the sound level meter	9.2.1 c) 9.2.5 b)	MS-11 → Connections, Calibration and Operation Check, Measurement
5.1.7	Mounting of microphone	9.2.1 b)	→ Connections
5.1.8	Identification of computer software		N/A
5.1.10	Description of frequency weightings that are provided	9.2.2 c)	A, C, Z
5.1.12	Description of level ranges (@ A- weighted SPL @ 1kHz ) Instruction manual of the level range controls and function. Recommendation for selecting the optimum level range.	9.2.2 h) 9.2.5 c)	28 dB to 138 dB  N/A  N/A
5.1.13	Reference SPL reference level range, Reference orientation, reference position of microphone.	9.2.5 a), 9.3 a), b), c)	94.0 dB N/A Fig. 1 Reference incidence direction and reference point position
5.1.14	Operating of the hold facility and the means for clearing a display that is held.		→ Measurement: Measurement of maximum time-weighted sound level $L_{\max}$
5.1.15	Dummy microphone: Design goal and tolerance	9.3 g)	Capacitance of dummy microphone: 12 pF Tolerance: $\pm 1.5$ pF
5.1.16	Highest SPL and Peak-Peak input voltage without causing damage.	9.3 i)	150 dB 30 V <sub>p-p</sub>
5.1.17	Characteristics of each independent channel to be described		N/A
5.1.18	Initial time interval after switching on power	9.2.5 e)	Less than 2 minutes.
<b>5.2</b>	<b>Adjustment to indicated levels</b>		
5.2.1	Model of sound calibrator(s)	9.2.4 a)	NC-74 (RION)

Standard paragraph	Description	See also	Remark
5.2.3	Procedure for calibration & adjustment with sound calibrator	9.2.4 c)	→ Calibration and Operation Check: Acoustic calibration with Sound Calibrator NC-74 94.0 dB
5.2.4 5.2.5	Data for correction - with and without windscreen - for : - Deviation of average frequency response to uniform frequency response. - Case reflection and microphone diffraction Including values for expanded uncertainties. In 1/3 octave frequencies for 63 Hz to 1 kHz and 1/12 octave frequencies for 1 kHz to 16 kHz	9.2.4 d) 9.2.5 b)	Fig. 2 Frequency response of the microphone MS-11 (including the case reflection) Fig. 4 Influence of WS-13 on acoustic performance of MS-11 Fig. 5 Frequency response with windscreen correction Refer to IEC61672-1 (JIS C 1509-1) Frequency Response
5.2.7	Adjustment data for sound calibrator or electrostatic actuator (for A-weighted sound levels)	9.3 d)	Tab. 1 Adjustment data for sound calibrator
<b>5.4</b>	<b>Frequency weightings</b>		
5.4.12	Frequency response & tolerances of optional frequency responses	9.2.2 c)	N/A
<b>5.5</b>	<b>Level linearity</b>		
5.5.9	A, C and Z weighted levels for the lower and upper limit of the linear operating range. - For frequencies 31.5 Hz, 1, 4, 8 and 12.5 kHz	9.3 e)	Tab. 2 The lower and upper limits of the linear operating range
5.5.10	Starting point for the level linearity error - For frequencies 31.5 Hz, 1, 4, 8 and 12.5 kHz - At a specified level range	9.3 f)	Tab. 2 The lower and upper limits of the linear operating range
5.5.11	How to test level linearity if display range < linearity range	9.3 k)	N/A
<b>5.6</b>	<b>Self generated noise</b>		
5.6.1	Self-noise at the more sensitive ranges (including microphone)	9.2.5 o) 9.3 h)	Maximum value A: <20 dB C: <28 dB Z: <34 dB Typical value (MS-11) A: 16 dB C: 20 dB Z: 28 dB

Standard paragraph	Description	See also	Remark
5.6.3	Self-noise at the more sensitive ranges with dummy microphone	9.3 h)	Dummy microphone (12 pF) Maximum value Equal to 5.6.1 Typical value A: 13 dB C: 17 dB Z: 23 dB
5.6.5	Instruction to measure low level sounds with consideration of influence of self-noise	9.2.5 d)	→ Technical Reference: Influence of Background Noise
<b>5.7</b>	<b>Time weighting F and S</b>		
5.7.1	Description of time weightings that are provided	9.2.2 d)	F, S
<b>5.10 - 5.11</b>	<b>Overload and Under-range indication</b>		
5.10.1	Operation & interpretation of overload indicators	9.2.5 k)	→ Controls and Functions: Display
5.11.1	Operation & interpretation of under-range indicators		→ Controls and Functions: Display
<b>5.12</b>	<b>Peak C sound level</b>		
5.12.1	Nominal range of $L_{Cpeak}$ at for each level range	9.2.2 i)	N/A
<b>5.14</b>	<b>Thresholds</b>		
5.14	Operation of user-selectable thresholds	9.2.5 l)	N/A
<b>5.15</b>	<b>Display</b>		
5.15.2	Description of the indication of displayed quantities	9.2.2 g)	→ Controls and Functions: Display
5.15.3	Description of the display	9.2.2 g)	→ Controls and Functions: Display
5.15.4	Description of the displayed quantities	9.2.2 a)	N/A
5.15.5	Statement of the display update rate	9.2.2 g)	1 second
5.15.6	Time interval for completion of the integration	9.2.5 f)	N/A
5.15.7	Description of method for transferring data to PC	9.2.5 m)	→ Connectors: Rear-panel connector, Wiring diagram → Serial Interface

Standard paragraph	Description	See also	Remark
<b>5.16</b>	<b>Analogue and digital outputs</b>		
5.16.1	Electric output connector (AC output)	9.2.5 p)	Frequency weighting: C Output voltage: 1 V <sub>rms</sub> (at 110 dB) Output range: 10 V <sub>rms</sub> or less Output impedance: 50 Ω Load impedance: >10 kΩ
	Electric output connector (DC output)		Frequency weighting: A, C, Z Output voltage: 5.5 V (at 130 dB), 50 mV/dB Output range: 0.4 to 5.9 V Output impedance: 50 Ω Load impedance: >10 kΩ
<b>5.17</b>	<b>Timing facilities</b>		
5.17.1	Procedure to preset the integration time & time of the day	9.2.5 g)	N/A
5.17.2	Statement of the minimum & maximum integration time	9.2.5 h)	N/A
<b>5.18</b>	<b>RF emissions and power supply disturbance</b>		
5.18.1	Length & type of interface cable and characteristics of connected devices	9.2.5 n)	Microphone extension cable EC-04 series (up to 35 m) Output cable NC-39A (1.5 m) All cables shielded
5.18.2	Operating mode or highest radio frequency emissions	9.3 n)	Operation mode: normal operation Connection pattern: AC adapter (with ferrite cores): RC45-12L Output cable (with ferrite cores): NC-39A 1.5 m Microphone extension cable (with ferrite cores): EC-04 series 35 m
<b>5.20</b>	<b>Power supply</b>		
5.20.2	Maximum and minimum power supply voltage	9.3 j)	Maximum: 15 V Minimum: 10 V
5.20.3	Battery types & battery life	9.2.3 a)	N/A
5.20.4	Operation from an external power supply	9.2.3 c)	N/A
5.20.5	Public power supply voltage	9.2.3 d)	100 to 240 V AC (tolerance range 90 to 264 V), 50/60 Hz (±3 Hz)
<b>6</b>	<b>Environmental, electrostatic and radio frequency criteria</b>		
6.1.2	Time interval for needed to stabilize after environmental changes	9.3 l)	Temperature change: < 1 hour Humidity change: < 1 hour Static pressure change: < 5 minutes
6.2.2 (Note)	Measurement when static pressure is < 85 kPa		Calibration and measurement performed in this environment using Sound Calibrator NC-74
6.5.2	Degradation of functions by electrostatic discharge	9.2.7 b)	Measurement value affected temporarily by electrostatic discharge



Standard paragraph	Description	See also	Remark
6.6.1	Operating mode with least immunity to AC power frequency fields and RF fields	9.3 o)	Fig. 6 Operation mode: normal operation Connection pattern: AC adapter (with ferrite cores): RC45-12L Output cable (with ferrite cores): NC-39A 1.5 m Microphone extension cable (with ferrite cores): EC-04 series 35 m
6.6.4 (Note)	Field strength for conforming (in case > 10 V/m)	9.3 m)	N/A
<b>7</b>	<b>Provisions for use with auxiliary devices</b>		
7.1	Correction for use of microphone cable	9.2.6 b)	N/A
7.2	Effect of optional accessories (windscreen)	9.2.6 a)	Directional Characteristics with WS-13 (Fig. 8)
7.3	Statement of conformance with optional accessories (windscreen)		Compliant with IEC 61672-1 (JIS C 1509-1), with Windscreen WS-13 mounted and windscreen correction ON
7.4	Operation of 1/1 - 1/3 octave band filters	9.2.6 c)	N/A
7.5	Details about connection & effects of auxiliary devices	9.2.6 d)	→ Connections
<b>9</b>	<b>Instruction manual</b>		
<b>9.2.1</b>	<b>General</b>		
9.2.1 a)	Description of type, classification (X, Y, Z) and class		Group Y, Class 1
9.2.1 b)	Overall configuration, Normal operation configuration (including windscreen)	5.1.4 5.1.7	Refer to 5.1.4 Refer to 5.1.7
9.2.1 c)	Models of microphones	5.1.6	Refer to 5.1.6
9.2.1 d)	Required microphone cable to conform		N/A
9.2.1 e)	Characteristics & operation each channel		N/A
<b>9.2.2</b>	<b>Design features</b>		
9.2.2 a)	Description of quantities which can be measured	5.15.4	time-weighted sound level maximum value of time-weighted sound level
9.2.2 b)	Relative free-field response as function of incidence angle and frequency (detailed tabular description)		Directional Characteristics of MS-11 (Fig. 7)
9.2.2 c)	Description of the frequency weightings	5.1.10 5.4.12	Refer to 5.1.10 Refer to 5.4.12
9.2.2 d)	Description of the time weightings	5.7.1	Refer to 5.7.1
9.2.2 e)	Identification of the level ranges (A-weighted @ 1 kHz)	5.1.12	Refer to 5.1.12

Standard paragraph	Description	See also	Remark
9.2.2 f)	Operation of the level range control	5.1.12	Refer to 5.1.12
9.2.2 g)	Description of the display and update rates	5.15.2-3-4-5	Refer to 5.15.2-3-4-5
9.2.2 h)	Total range of A- weighted SPL (@ 1 kHz)	5.1.12	Refer to 5.1.12
9.2.2 i)	Nominal range of $L_{Cpeak}$ at for each level range	5.12.1	Refer to 5.12.1
9.2.2 j)	Computer software to operate the SLM	5.1.8	Refer to 5.1.8
9.2.2 k)	Design goals and tolerances for quantities which are not in the standard (T-weight 10 ms, LAIeq)		N/A
<b>9.2.3</b>	<b>Power supply</b>		
9.2.3 a)	Battery types & battery life	5.20.3	Refer to 5.20.3
9.2.3 b)	Description of the function of battery check		→ Controls and Functions: Display
9.2.3 c)	Operation from an external power supply	5.20.4	Refer to 5.20.4
9.2.3 d)	Public power supply voltage	5.20.5	Refer to 5.20.5
<b>9.2.4</b>	<b>Adjustment to indicated levels</b>		
9.2.4 a)	Model of sound calibrator(s)	5.2.1	Refer to 5.2.1
9.2.4 b)	Calibration check frequency		1 kHz
9.2.4 c)	Procedure for calibration & adjustment with sound calibrator	5.2.3	Refer to 5.2.3
9.2.4 d)	Data for correction - with and without windscreen - for : - Deviation of average frequency response to uniform frequency response. - Case reflection and microphone diffraction Including values for expanded uncertainties. In 1/3 octave frequencies for 63 Hz to 1 kHz and 1/12 octave frequencies for 1 kHz to 16 kHz	5.2.4 - 5.2.5	Refer to 5.2.4 - 5.2.5
<b>9.2.5</b>	<b>Operating the sound level meter</b>		
9.2.5 a)	Reference direction	5.1.13	Refer to 5.1.13
9.2.5 b)	Procedure to measure sound, Influence of the instrument case and operator.	5.1.6 5.2.4 5.2.5	Refer to 5.1.6 Refer to 5.2.4 Refer to 5.2.5
9.2.5 c)	Recommendation for selecting optimum level range	5.1.12	Refer to 5.1.12
9.2.5 d)	Instruction to measure low level sounds with consideration of influence of self-noise	5.6.5	Refer to 5.6.5

Standard paragraph	Description	See also	Remark
9.2.5 e)	Initial time interval after switching on power	5.1.18	Refer to 5.1.18
9.2.5 f)	Time interval for completion of the integration	5.15.6	Refer to 5.15.6
9.2.5 g)	Procedure to preset the integration time & time of the day	5.17.1	Refer to 5.17.1
9.2.5 h)	Statement of the minimum & maximum integration time	5.17.2	Refer to 5.17.2
9.2.5 i)	Operation of the "Hold" function		→ Measurement: Measurement of maximum time-weighted sound level
9.2.5 j)	Operation of the reset function or <i>Leq</i> , <i>LE</i> , <i>Lpeak</i> and overload		Measurement results (measurement values, overload indication, under-range indication) are reset when a new measurement is started. Time required for measurement initialization: < 1 second
9.2.5.k)	Operation & interpretation of overload indicators	5.10.1	Refer to 5.10.1
9.2.5 l)	Operation of user-selectable thresholds	5.14	Refer to 5.14
9.2.5 m)	Description of method for transferring data to PC	5.15.7	Refer to 5.15.7
9.2.5 n)	Length & type of interface cable and characteristics of connected devices	5.18.1	Refer to 5.18.1
9.2.5 o)	Self-noise at the more sensitive ranges (including microphone). Averaging time $\geq 30$ s.	5.6.1	Refer to 5.6.1
9.2.5 p)	Characteristics of AC and DC output	5.16.1	Refer to 5.16.1
<b>9.2.6</b>	<b>Accessories</b>		
9.2.6 a)	Effect of windscreen (directional response and frequency weighting)	7.2	Refer to 7.2
9.2.6 b)	Corrections for microphone cable	7.1	Refer to 7.1
9.2.6 c)	Use of bandpass filters	7.4	Refer to 7.4
9.2.6 d)	Connection of auxiliary devices	7.5	Refer to 7.5
<b>9.2.7</b>	<b>Influence of environmental conditions</b>		
9.2.7 a)	Components intended for operation in controlled environment		None
9.2.7 b)	Degradation of functions by electrostatic discharge	6.5.2	Refer to 6.5.2
9.2.7 c)	Statement for conformance to AC power frequency fields and RF fields		Statement of conforming to the basic statement (Tab. 5)

Standard paragraph	Description	See also	Remark
<b>9.3</b>	<b>Information for testing</b>		
9.3 a)	Reference sound pressure level	5.1.13	Refer to 5.1.13
9.3 b)	Reference level range	5.1.13	Refer to 5.1.13
9.3 c)	Microphone reference point	5.1.13	Refer to 5.1.13
9.3 d)	For A-weighted sound levels: Adjustment data for multi-frequency sound calibrator and/or electrostatic actuator	5.2.7	Refer to 5.2.7
9.3 e)	Nominal A-weighted sound levels at the upper and lower limits of the linear operating range on each level range. - For frequencies 31.5 Hz, 1, 4, 8 and 12.5 kHz	5.5.9	Refer to 5.5.9
9.3 f)	Starting point for the level linearity error - For frequencies 31.5 Hz, 1, 4, 8 and 12.5 kHz - At the reference level range	5.5.10	Refer to 5.5.10
9.3 g)	Dummy microphone: Design goal and tolerance	5.1.15	Refer to 5.1.15
9.3 h)	Self-noise at the more sensitive ranges with microphone and with dummy microphone	5.6.1 / 5.6.3	Refer to 5.6.1 / 5.6.3
9.3 i)	Highest SPL and Peak-Peak input voltage to accommodate	5.1.16	Refer to 5.1.16
9.3 j)	Maximum and minimum power supply voltage	5.20.2	Refer to 5.20.2
9.3 k)	How to test level linearity if display range < linearity range	5.5.11	Refer to 5.5.11
9.3 l)	Time interval for needed to stabilize after environmental changes	6.1.2	Refer to 6.1.2
9.3 m)	Field strength for conforming (in case > 10 V/m)	6.6.4	Refer to 6.6.4
9.3 n)	Operating mode or highest radio frequency emissions	5.18.2	Refer to 5.18.2
9.3 o)	Operating mode with least immunity to AC power frequency fields and RF fields	6.6.1	Refer to 6.6.1

## IEC61672-1 (JIS C 1509-1) Frequency Response

Nominal frequency (Hz)	Exact frequency (Hz)	MS-11 Frequency Response (dB)	Electrical Response (dB)	Wind-screen effect (dB)	Wind-screen correction (dB)	Wind-screen combined (dB)	Total Response (Wind-Screen combined) (dB)	Total expanded uncertainty (dB)
63	63.10	0.3	-0.1	0.0	0.0	0.0	0.2	0.3
80	79.43	0.3	-0.1	0.0	0.0	0.0	0.2	0.3
100	100.0	0.2	-0.1	0.1	0.0	0.1	0.2	0.3
125	125.9	0.2	0.0	0.1	0.0	0.1	0.3	0.3
160	158.5	0.2	0.0	0.1	-0.1	0.0	0.2	0.3
200	199.5	0.2	0.0	0.1	-0.1	0.0	0.2	0.3
250	251.2	0.1	0.0	0.2	-0.1	0.1	0.2	0.2
315	316.2	0.1	0.0	0.2	-0.2	0.0	0.1	0.2
400	398.1	0.2	0.0	0.3	-0.3	0.0	0.2	0.2
500	501.2	0.1	0.0	0.3	-0.3	0.0	0.1	0.2
630	631.0	0.1	0.0	0.4	-0.4	0.0	0.1	0.2
800	794.3	0.1	0.0	0.4	-0.5	-0.1	0.0	0.2
1 000	1 000.0	0.0	0.0	0.5	-0.5	0.0	0.0	0.2
1 060	1 059.3	0.0	0.0	0.4	-0.5	-0.1	-0.1	0.2
1 120	1 122.0	0.0	0.0	0.5	-0.5	0.0	0.0	0.2
1 180	1 188.5	0.0	0.0	0.4	-0.5	-0.1	-0.1	0.2
1 250	1 258.9	0.0	0.0	0.4	-0.5	-0.1	-0.1	0.2
1 320	1 333.5	-0.1	0.0	0.4	-0.5	-0.1	-0.2	0.3
1 400	1 412.5	-0.1	0.0	0.4	-0.5	-0.1	-0.2	0.3
1 500	1 496.2	0.0	0.0	0.5	-0.5	0.0	0.0	0.3
1 600	1 584.9	0.1	0.0	0.4	-0.5	-0.1	0.0	0.3
1 700	1 678.8	0.1	0.0	0.4	-0.4	0.0	0.1	0.3
1 800	1 778.3	0.0	0.0	0.3	-0.4	-0.1	-0.1	0.3
1 900	1 883.6	0.0	0.0	0.3	-0.4	-0.1	-0.1	0.3
2 000	1 995.3	0.1	0.0	0.4	-0.4	0.0	0.1	0.3
2 120	2 113.5	0.2	0.0	0.3	-0.4	-0.1	0.1	0.3
2 240	2 238.7	0.1	0.0	0.3	-0.3	0.0	0.1	0.3
2 360	2 371.4	0.1	0.0	0.3	-0.3	0.0	0.1	0.3
2 500	2 511.9	0.1	0.0	0.2	-0.3	-0.1	0.0	0.3
2 650	2 660.7	-0.1	0.0	0.2	-0.3	-0.1	-0.2	0.3

Nominal frequency (Hz)	Exact frequency (Hz)	MS-11 Frequency Response (dB)	Electrical Response (dB)	Wind-screen effect (dB)	Wind-screen correction (dB)	Wind-screen combined (dB)	Total Response (Wind-Screen combined) (dB)	Total expanded uncertainty (dB)
2 800	2 818.4	-0.2	0.0	0.2	-0.2	0.0	-0.2	0.3
3 000	2 985.4	-0.2	0.0	0.1	-0.2	-0.1	-0.3	0.3
3 150	3 162.3	-0.2	0.0	0.2	-0.2	0.0	-0.2	0.3
3 350	3 349.7	0.0	0.0	0.2	-0.2	0.0	0.0	0.3
3 550	3 548.1	0.2	0.0	0.2	-0.1	0.1	0.3	0.3
3 750	3 758.4	0.3	0.0	0.0	-0.1	-0.1	0.2	0.3
4 000	3 981.1	0.1	0.0	0.0	-0.1	-0.1	0.0	0.3
4 250	4 217.0	0.0	0.0	0.0	-0.1	-0.1	-0.1	0.3
4 500	4 466.8	-0.1	0.0	-0.1	-0.1	-0.2	-0.3	0.3
4 750	4 731.5	-0.2	0.0	0.1	-0.1	0.0	-0.2	0.3
5 000	5 011.9	-0.1	0.0	0.0	-0.1	-0.1	-0.2	0.3
5 300	5 308.8	-0.2	0.0	-0.1	-0.1	-0.2	-0.4	0.3
5 600	5 623.4	0.1	0.0	-0.1	-0.1	-0.2	-0.1	0.3
6 000	5 956.6	0.0	0.0	-0.1	-0.1	-0.2	-0.2	0.3
6 300	6 309.6	-0.1	0.0	0.0	-0.1	-0.1	-0.2	0.3
6 700	6 683.4	0.1	0.0	-0.3	-0.2	-0.5	-0.4	0.3
7 100	7 079.5	0.1	0.0	0.0	-0.2	-0.2	-0.1	0.3
7 500	7 498.9	0.2	0.0	-0.3	-0.2	-0.5	-0.3	0.3
8 000	7 943.3	0.3	0.0	-0.2	-0.3	-0.5	-0.2	0.3
8 500	8 414.0	0.3	0.0	0.1	-0.3	-0.2	0.1	0.3
9 000	8 912.5	0.3	0.0	-0.1	-0.4	-0.5	-0.2	0.3
9 500	9 440.6	0.1	0.0	-0.1	-0.5	-0.6	-0.5	0.3
10 000	10 000.0	0.5	0.0	-0.5	-0.5	-1.0	-0.5	0.3
10 600	10 592.5	0.6	0.0	-0.6	-0.6	-1.2	-0.6	0.5
11 200	11 220.2	0.4	0.0	-0.3	-0.6	-0.9	-0.5	0.5
11 800	11 885.0	0.8	0.0	-0.5	-0.7	-1.2	-0.4	0.5
12 500	12 589.3	0.7	0.0	-0.6	-0.8	-1.4	-0.7	0.5
13 200	13 335.2	0.8	0.0	-0.8	-0.8	-1.6	-0.8	0.5
14 000	14 125.4	0.6	0.0	-0.9	-0.9	-1.8	-1.2	0.5
15 000	14 962.4	0.7	0.0	-0.6	-0.9	-1.5	-0.8	0.5
16 000	15 848.9	0.3	0.0	-0.9	-1.0	-1.9	-1.6	0.5

## Reference incidence direction and reference point position

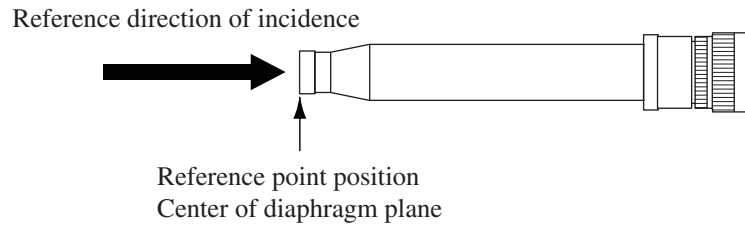

Fig. 1 Reference incidence direction and reference point position

## Frequency Response

The frequency response of a sound field microphone is expressed as the frequency response in the reference direction of incidence (0°).

The diagram below shows an example for the frequency response of the microphone MS-11.

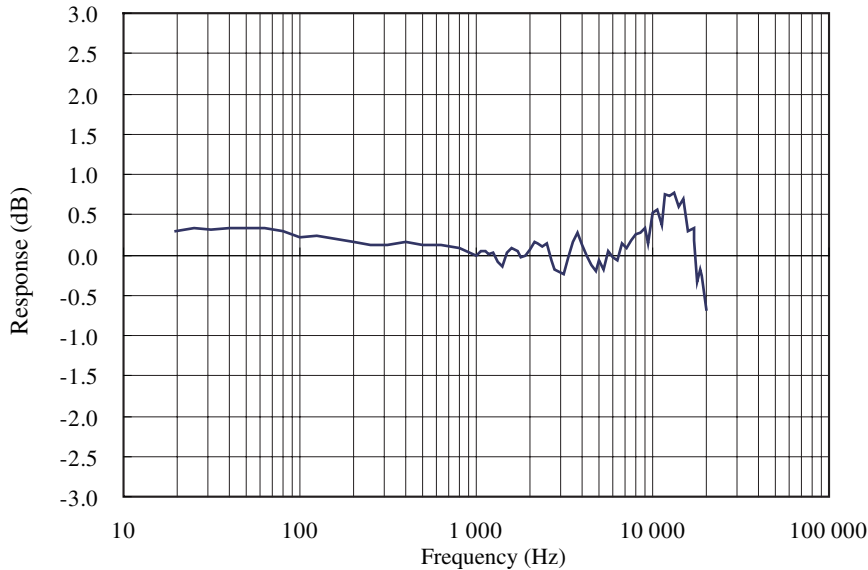

Fig. 2 Frequency response of the microphone MS-11

## Effect of All-Weather Windscreen WS-13

The windscreen WS-13 not only reduces measurement errors due to wind noise, it also protects the microphone from rain.

The WS-13 characteristics are shown below.

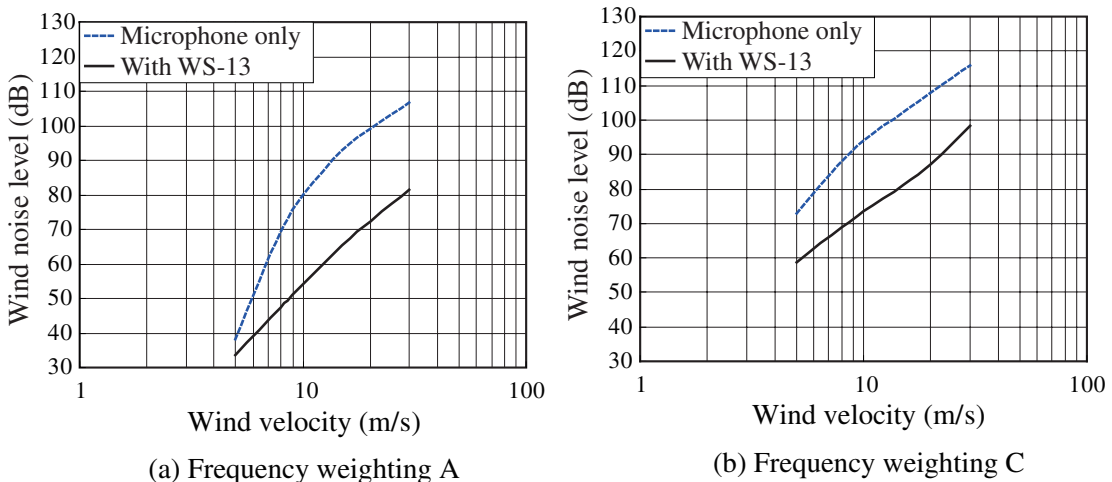

Fig. 3 Wind noise reduction effect



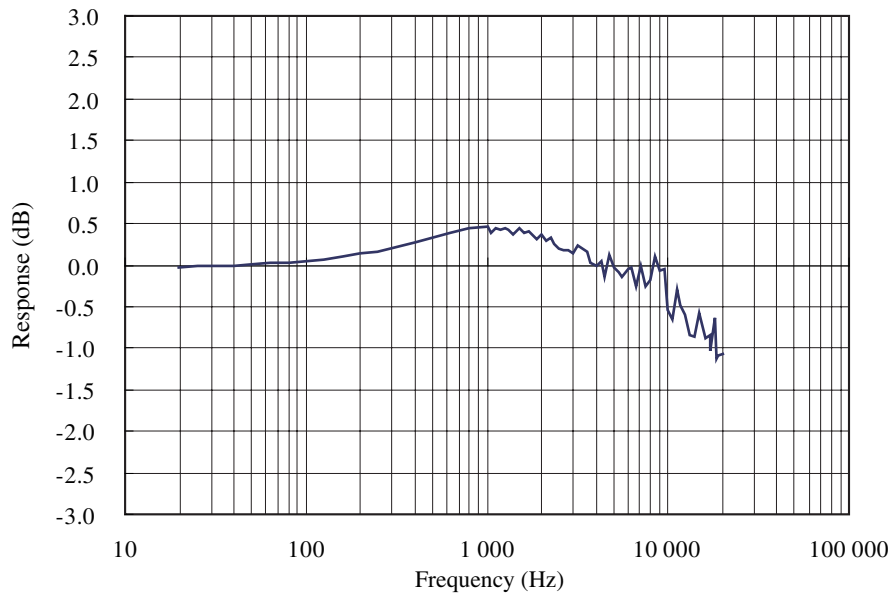

Fig. 4 Influence of WS-13 on acoustic performance of MS-11  
(Referenced to microphone-only characteristics)

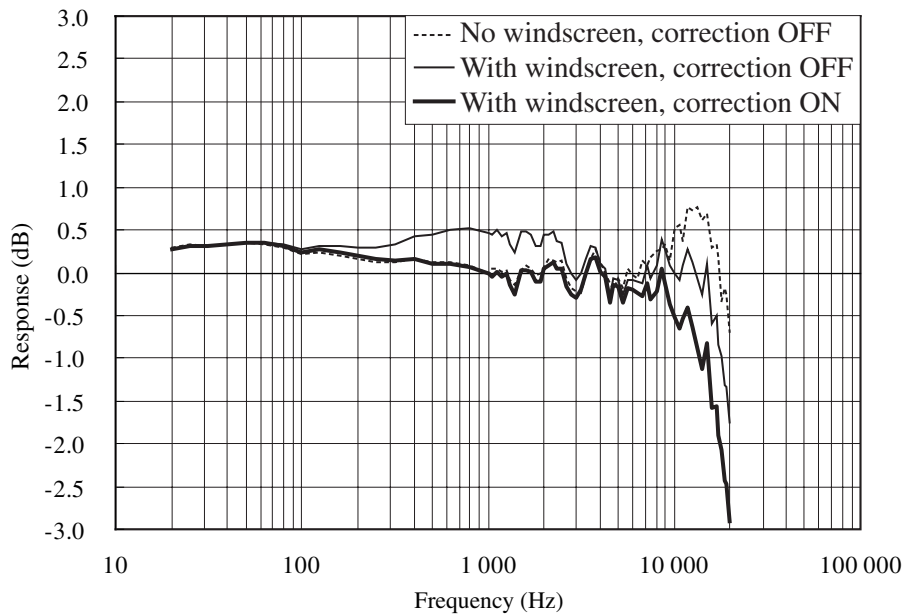

Fig. 5 Frequency response with windscreen correction

## The greatest susceptibility configuration for radio frequency fields

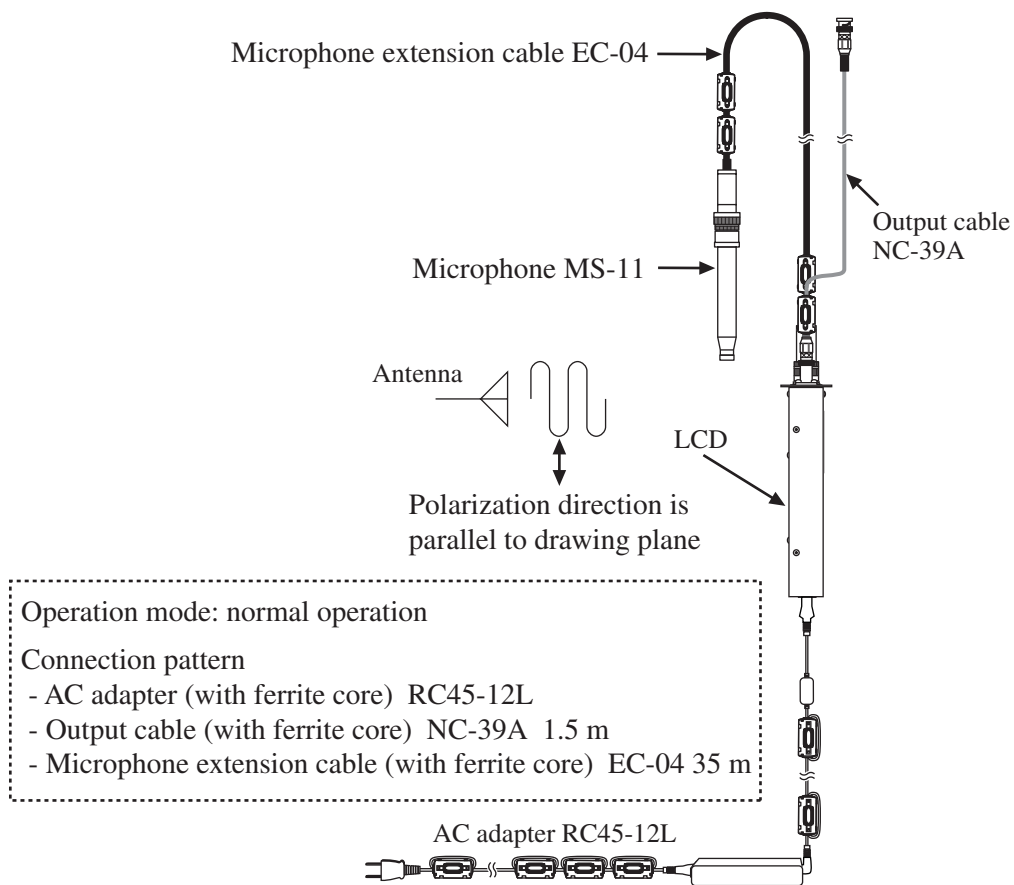

Fig. 6 The greatest susceptibility configuration for radio frequency fields

## Frequency response adjustment data for periodic test

Tab. 1 Adjustment data for sound calibrator

Frequency (Hz)	Correction (dB)
31.5	-0.2
63	-0.2
125	-0.2
250	-0.2
500	-0.1
1 000	0.0
2 000	0.1
4 000	0.8
8 000	2.7
12 500	5.8
16 000	7.5

## The lower and upper limits of the linear operating range

Tab. 2 The lower and upper limits of the linear operating range

A-weighting

Frequency (Hz)		Sound level (dB)				
		31.5	1 k	4 k	8 k	12.5 k
Upper	Microphone extension cable 5 m	98.0	138.0	137.0	134.0	131.0
	Microphone extension cable 10 m	98.0	138.0	137.0	134.0	131.0
	Microphone extension cable 35 m	98.0	138.0	136.0	131.0	124.0
Start		54.0	94.0	94.0	94.0	94.0
Lower		28.0	28.0	28.0	28.0	28.0

C-weighting

Frequency (Hz)		Sound level (dB)				
		31.5	1 k	4 k	8 k	12.5 k
Upper	Microphone extension cable 5 m	135.0	138.0	137.0	134.0	131.0
	Microphone extension cable 10 m	135.0	138.0	137.0	133.0	129.0
	Microphone extension cable 35 m	135.0	138.0	135.0	130.0	122.0
Start		94.0	94.0	94.0	94.0	94.0
Lower		46.0	36.0	36.0	36.0	36.0

Z-weighting

Frequency (Hz)		Sound level (dB)				
		31.5	1 k	4 k	8 k	12.5 k
Upper	Microphone extension cable 5 m	138.0	138.0	138.0	138.0	137.0
	Microphone extension cable 10 m	138.0	138.0	138.0	138.0	136.0
	Microphone extension cable 35 m	138.0	138.0	136.0	132.0	129.0
Start		94.0	94.0	94.0	94.0	94.0
Lower		52.0	42.0	42.0	42.0	42.0

## **Directional Characteristics**

The directional characteristics of a microphone is a measure of its differing sensitivity for sound waves arriving from various angles. Since the prepolarized condenser microphone used in the MS-11 is a pressure-sensitive type, it should be equally sensitive in all directions. However, refraction and cavity effects cause a certain microphone directional response at high frequencies.

The diagrams on following pages shows the directional characteristics for the MS-11 and for the MS-11 with windscreen WS-13.

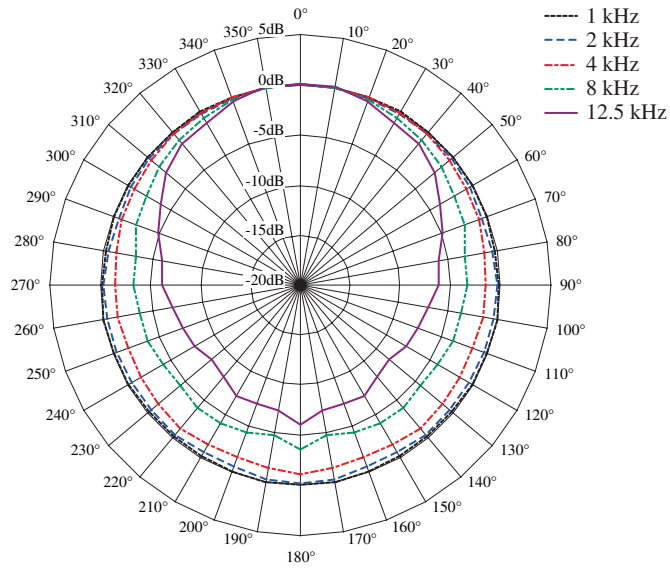

Fig. 7 Directional Characteristics of MS-11

Tab. 3 Directional Characteristics of MS-11

Angle	Frequency [Hz]				
	1k	2k	4k	8k	12.5k
0°	0.0	0.0	0.0	0.0	0.0
10°	0.0	-0.1	0.0	-0.1	0.1
20°	0.0	-0.2	-0.1	-0.3	-0.4
30°	-0.1	-0.3	-0.2	-0.7	-1.3
40°	-0.1	-0.4	-0.4	-1.1	-1.7
50°	-0.1	-0.4	-0.6	-1.6	-2.5
60°	-0.2	-0.5	-0.9	-2.3	-4.0
70°	-0.3	-0.7	-1.0	-2.6	-4.9
80°	-0.3	-0.6	-1.3	-3.3	-5.9
90°	-0.2	-0.4	-1.5	-3.3	-6.2
100°	-0.1	-0.4	-1.5	-3.7	-7.0
110°	-0.2	-0.5	-1.6	-3.8	-7.5
120°	-0.3	-0.6	-1.6	-4.3	-7.9
130°	-0.4	-0.5	-1.5	-4.3	-8.4
140°	-0.4	-0.4	-1.3	-4.0	-8.0
150°	-0.3	-0.7	-1.6	-4.1	-7.2
160°	-0.2	-0.7	-1.6	-4.3	-7.3
170°	-0.1	-0.3	-1.5	-4.8	-7.4
180°	-0.1	-0.2	-1.1	-3.6	-6.1

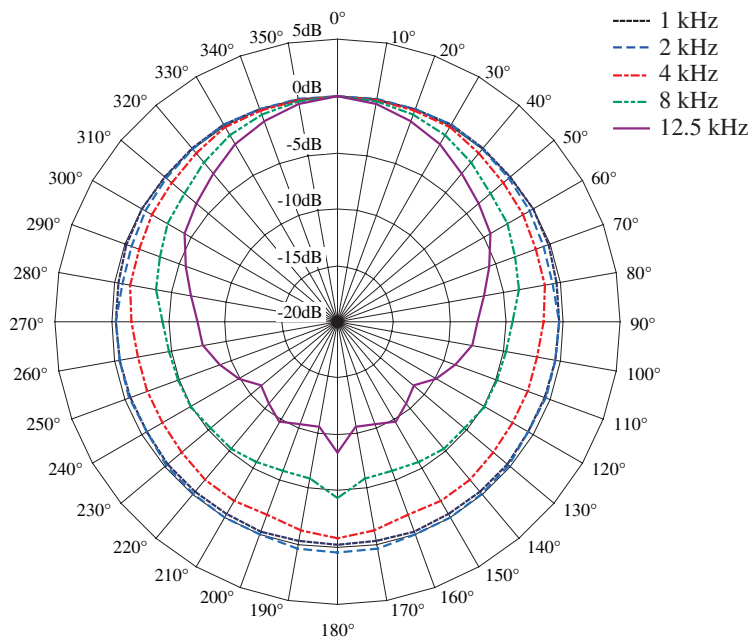

Fig. 8 Directional Characteristics with WS-13

Tab. 4 Directional Characteristics with WS-13

Angle	Frequency [Hz]				
	1k	2k	4k	8k	12.5k
0°	0.0	0.0	0.0	0.0	0.0
10°	0.0	0.0	-0.1	-0.1	-0.4
20°	0.0	0.0	-0.2	-0.5	-1.1
30°	0.1	0.1	-0.2	-1.0	-1.9
40°	0.1	0.0	-0.5	-1.7	-2.9
50°	0.0	-0.3	-0.9	-2.3	-3.7
60°	0.0	-0.4	-1.1	-2.7	-4.4
70°	-0.1	-0.6	-1.3	-3.3	-5.8
80°	-0.3	-0.6	-1.4	-3.7	-6.8
90°	-0.4	-0.4	-1.8	-4.5	-7.7
100°	-0.4	-0.4	-2.1	-4.8	-7.8
110°	-0.5	-0.4	-2.2	-4.9	-8.8
120°	-0.5	-0.5	-2.2	-5.0	-10.0
130°	-0.4	-0.3	-2.0	-5.3	-11.2
140°	-0.4	-0.1	-1.8	-5.3	-10.6
150°	-0.4	-0.1	-1.8	-5.7	-9.7
160°	-0.3	0.1	-1.8	-6.0	-10.4
170°	-0.3	0.4	-1.3	-5.9	-10.6
180°	-0.2	0.4	-0.9	-4.4	-8.4

## Random incidence response

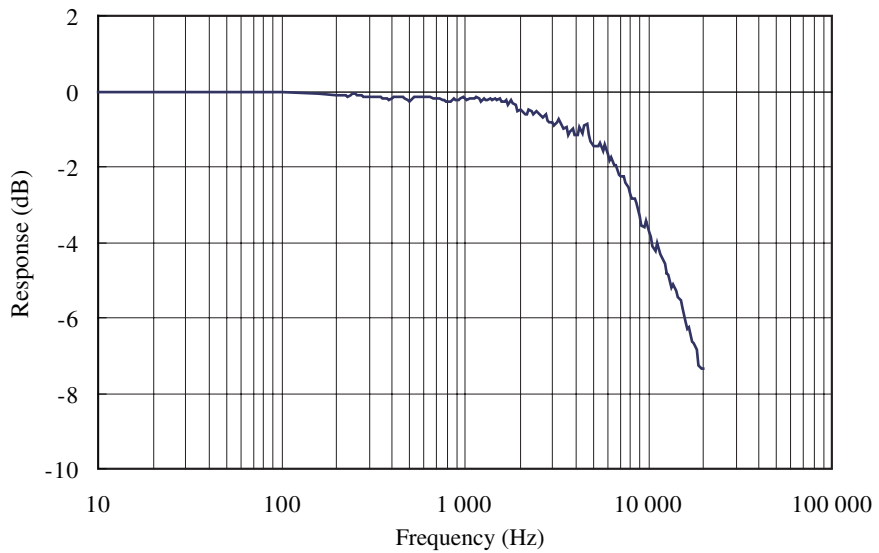

Fig. 9 Random incidence response (only MS-11)

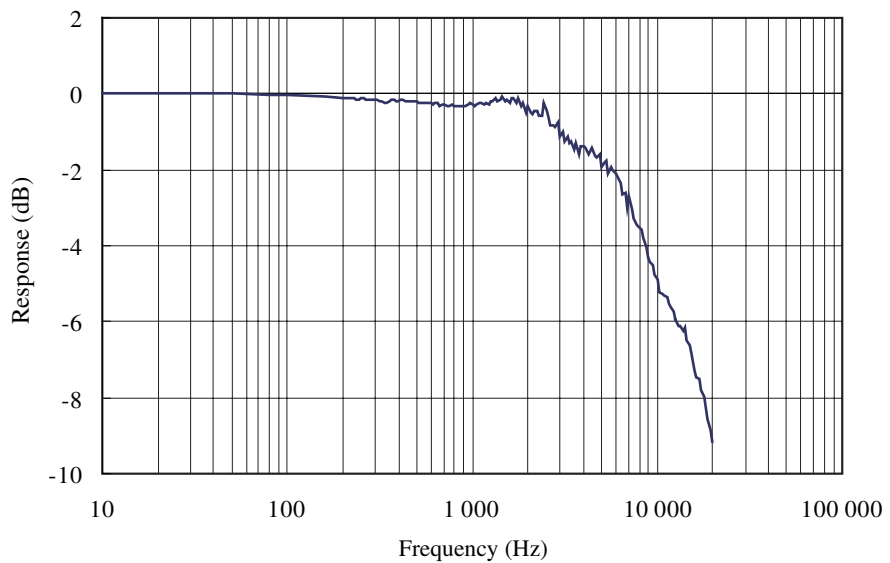

Fig. 10 Random incidence response (with WS-13)

## Statement of conforming to the basic statement

Tab. 5 Statement of conforming to the basic statement

Immunity (a.c. power frequency field)	The specification of IEC 61672-1 Class 1 is satisfied
Immunity (Radio frequency field)	The specification of IEC 61672-1 Class 1 is satisfied
Emission	The specification of IEC 61672-1 Class 1 is satisfied

# Specifications

## Applicable standards

Measurement Law -precision sound level meters

IEC 61672-1:2002 Class 1 (JIS C 1509-1:2005 Class 1)

(Microphone extension cable length max. 35 m)

CE marking

(EMC Directive: 2004/108/EC EN61326-1:2006/IEC 61326-1:2005)

(Microphone extension cable length max. 30 m)

WEEE Directive

## Measurement functions

Measurement items

Display data Time-weighted sound level  $L_p$

Maximum time-weighted sound level  $L_{max}$

Data output via serial interface

$L_p, L_{max}, L_{min}, L_{eq}$  for every 100 ms

Measurement level range

A-weighting 28 to 138 dB

C-weighting 36 to 138 dB

Z-weighting 42 to 138 dB

Total range (A-weighting, 1 kHz) 28 to 138 dB

Self-generated noise

A-weighting max. 20 dB

C-weighting max. 28 dB

Z-weighting max. 34 dB

Measurement frequency range

20 Hz to 20 kHz

Frequency weighting

A, C, Z

Time weighting F (Fast), S (Slow)

Linear operating range

110 dB

Level range switching

None



Bar graph indication range

30 to 130 dB

RMS detection digital processing (sampling cycle 20.8  $\mu$ s)

Reference frequency 1 kHz

Reference sound pressure level

94 dB

Reference conditions

Ambient temperature

23°C

Relative humidity

50%

Static pressure

101.325 kPa

Microphone and preamplifier

Outdoor Microphone MS-11

Sensitivity

-29 dB (re. 1 V/Pa, in reference conditions)

Calibration

Acoustic calibration with microphone integrated sound source (compliant with Measurement Law)

Calibration level 114 dB

Frequency 1 kHz

Calibration with external sound calibrator (Compliant with IEC 61672-1:2002 Class 1, JIS C 1509-1:2005 Class 1)

Model NC-74

Calibration level 94 dB

Frequency 1 kHz

Operation check with microphone integrated sound source

Temperature characteristics of integrated sound source

(-10°C to +50°C range, referenced to 23°C, atmospheric pressure 101.325 kPa)

Frequency 1 kHz

Sound pressure level 114.0 dB  $\pm$ 0.3 dB

## Frequency characteristics of microphone integrated sound source

(-10°C to +50°C range, referenced to 1 kHz, atmospheric pressure 101.325 kPa)

250 Hz ±0.5 dB

500 Hz ±0.5 dB

4 kHz ±1.5 dB

## Windscreen correction function

Corrects frequency response for compliance with standard requirements also when All-Weather Windscreen WS-13 is mounted.

On/Off selectable by key operation or remote command

## Display

TN positive display, reflective

Numeric readout 0.1 dB resolution (display update cycle 1 s)

Bar graph 100 dB range, 5 dB resolution (display update cycle 0.1 s)

## Warning indications

Over-range indicator appears at 139 dB (at 1 kHz)

Under-range indicator appears at -0.6 dB from lower measurement limit

## Input/output connectors

## AC/DC output connector

AC or DC output, selectable by key operation or remote command

AC output Frequency weighting C-weighting

Output voltage 1 V<sub>rms</sub> (at 110 dB)

Maximum output voltage

10 V<sub>rms</sub> (at 130 dB, 1 kHz)

Output impedance 50 Ω

Load impedance 10 kΩ or higher

DC output Output voltage 5.5 V (at 130 dB), 50 mV/dB

Output impedance 50 Ω

Load impedance 10 kΩ or higher

## Connection to NA-37

### Power supply to NA-83

See power requirements section

### NA-83 hard reset signal handling

Reset triggered when NA-37 open-collector output is ON

### NA-83 control by NA-37 and data output (serial communication)

#### Transfer protocol

Sync. principle	asynchronous
Data word length	8 bit
Stop bits	1 bit
Parity check	none
Baud rate	19200 bps
Flow control	yes

#### NA-83 control

#### NA-83 data output

Output data	$L_p, L_{\max}, L_{\min}, L_{\text{eq}}$
Output cycle	100 ms

## Power requirements

### Rated power supply voltage

12 V DC

### Operation voltage range

10 to 15 V DC

AC adapter RC45-12L

### Current consumption

approx. 200 mA (at 12 V DC)

## Environmental conditions for operation

### Sound level meter unit

-10°C to +50°C, 10 to 90% RH

### Microphone MS-11

Operating -20°C to +50°C, 10 to 100% RH (no condensation)

Storage -10°C to +50°C, 10 to 90% RH

Dimensions and mass 135 × 172.3 × 41 mm, 520 g (including MS-11)

## Supplied accessories

Outdoor Microphone MS-11	1
Ferrite core FCA8K (for microphone extension cable)	3
MS-11 storage case	1
MS-11 calibration chart	1
Instruction manual	1
Communication connector 8300-032-281 (KEL)	1
Inspection certificate	1

## Optional accessories

Sound Calibrator NC-74

Pistonphone NC-72A

All-Weather Windscreen WS-13

Microphone Extension Cable EC-04 series

EC-04, EC-04A, EC-04B (maximum cable length for  
CE marking compliance: 30 meters)

EC-04C, EC-04D, EC-04E (no CE marking compli-  
ance)

BNC-BNC cable NC-39A (1.5 m)

AC adapter RC45-12L (third-party accessory, Futaba Electric)

Ferrite core FCA8K (Morimiya Electric)

For NC-39A 1

For RC45-12L 6

All-Weather Windscreen Tripod ST-81

All-Weather Windscreen Tripod ST-88 (for roof mounting)

## Outdoor Microphone MS-11 Specifications

Frequency response	Free-field type
Microphone cartridge	1/2 inch electret condenser microphone
Overall characteristics	for microphone and preamplifier
Sensitivity	-29 dB (typical) (re 1 V/Pa at 1 kHz, in reference conditions)
Output impedance	300 $\Omega$ or less
Maximum input sound pressure level	138 dB (at 1 kHz)
Self-generated noise level	20 dB or less (A-weighting)
Power supply voltage	$\pm 12$ to $\pm 18$ V
Current consumption	max. 5 mA
Frequency range	20 Hz to 20 kHz
Temperature dependent sensitivity level fluctuation	max. $\pm 0.4$ dB from $-10^{\circ}\text{C}$ to $+50^{\circ}\text{C}$ , referenced to sensitivity at $23^{\circ}\text{C}$
Humidity dependent sensitivity level fluctuation	max. $\pm 0.14$ dB at humidity up to 90%, referenced to sensitivity at $23^{\circ}\text{C}$ and 50% RH (no condensation)
Atmospheric pressure dependent sensitivity level fluctuation	$\pm 0.4$ dB in range from 85 to 108 kPa, referenced to sensitivity at 101.325 kPa $\pm 0.9$ dB or less in range from 65 to 85 kPa
Microphone integrated sound source	
Signal frequencies	250 Hz, 500 Hz, 1 kHz, 4 kHz
Allowable input voltage	3.5 Vrms

Heater

Heater power consumption

0.9 W (typical with input current 94 mA DC)

Heater electrical resistance

102  $\Omega$  (typical)

Ambient temperature/humidity conditions for operation

-20°C to +50°C, 10 to 100% RH (no condensation)

Dimensional drawing See Fig. 2

Mass approx. 120 g

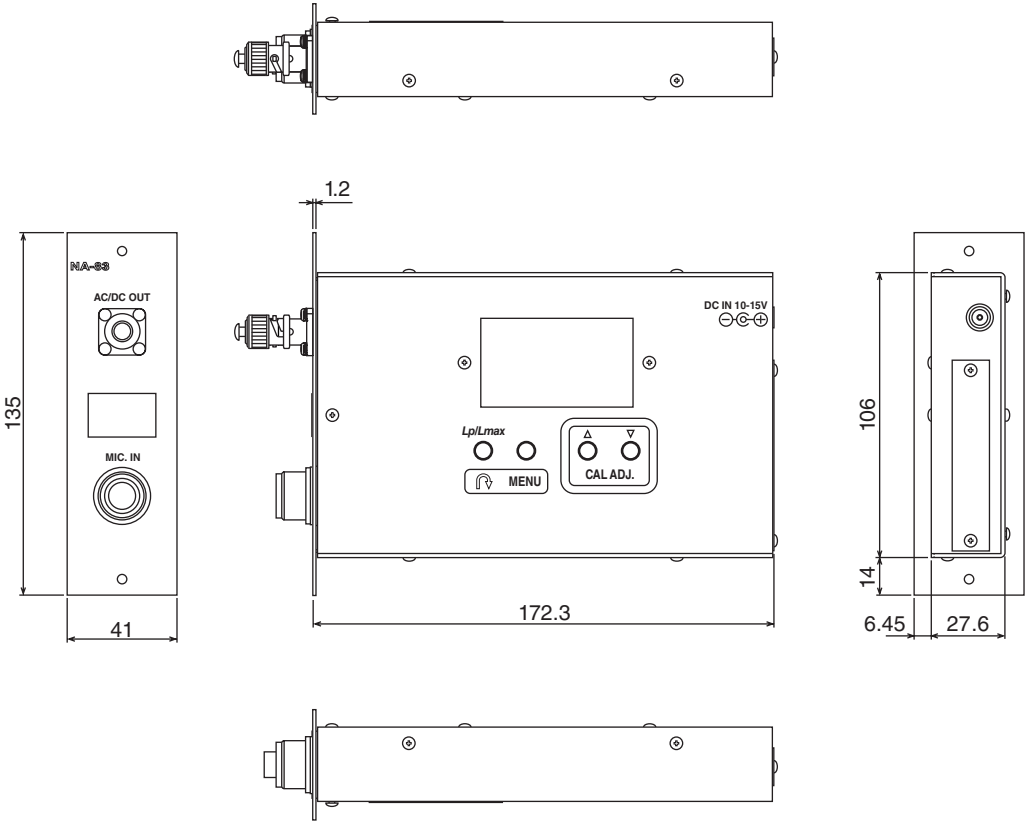

Unit: mm

Fig. 1 NA-83 Dimensional Drawings

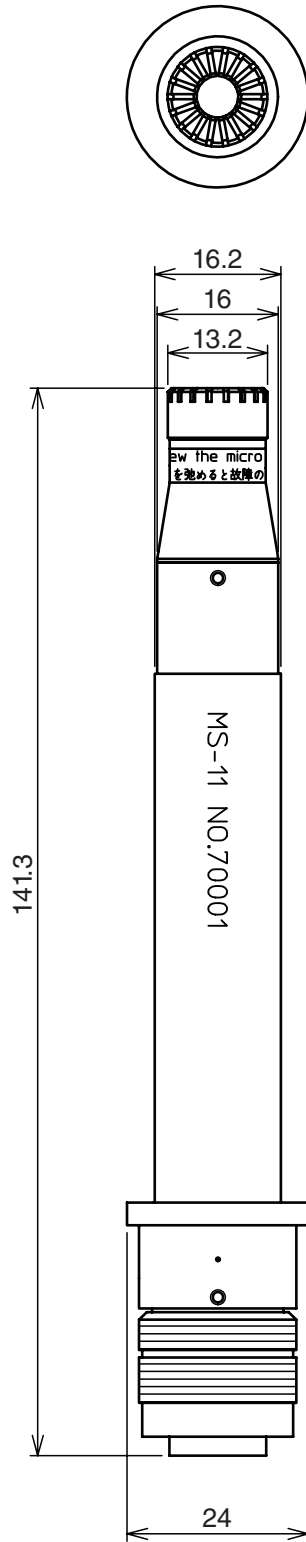

Unit: mm

Fig. 2 MS-11 Dimensional Drawings



# Serial Interface

The NA-83 incorporates a serial interface which can be used to set up and control the unit using commands sent from a computer, and to transfer measurement data to the computer.

This section explains how to use the interface for RS-232C communication. For information on how to connect to a computer, see page 39.

This section covers the following items.

1. Transfer format and protocol

Explains the RS-232C interface transfer format and the procedure

2. Commands

Explains the commands that can be used to control the NA-83. First, the command format is explained, followed by a list of commands and a description of the individual commands.

# Transfer Format and Protocol

## Transfer protocol

The unit uses the following transfer protocol.

Communication principle:	Full duplex
Sync. principle:	Asynchronous
Baud rate:	19200 bps
Data word length:	8 bit
Stop bits:	1 bit
Parity check:	none
Flow control:	X parameter
Command response:	yes

## Local Mode/Remote Mode

Mode	Key operation	Communication
Remote	Disabled	Enabled
Local	Enabled	Enabled

### Local mode

In this mode, the NA-83 can be operated normally with the keys on the unit. This mode is always active after power-on. Communication is also possible in this mode.

### Remote mode

In this mode, the NA-83 cannot be operated with the keys on the unit. In remote mode, the center “80” segment of the bar graph is out.

### Switching between local mode and remote mode

The RMT command is used to switch between local mode and remote mode.

## Transfer codes

The codes used for communication with the NA-83 are as follows.

### Control codes

Code	Hexadecimal notation	Meaning
<ACK>	06H	Acknowledge
<NAK>	15H	Not Acknowledge
<STX>	02H	Start Block
<ETX>	03H	End Block
<CR>	0DH	Terminator, 1st character
<LF>	0AH	Terminator, 2nd character
<SUB>	1AH	Stop

### Special codes

ATTR	Control Code or Character Code	Block Attribute
BCC	00H to FFH	Block Check Code

Command, parameter, data

ASCII code 20H to 7EH

## Transfer format

Command block:

Command from computer

<STX>	01H	ATTR	Command	Parameter	<ETX>	00H	<CR>	<LF>
1	1	1	M	N	1	1	1	1 byte

\* ATTR = 'C'

Data response block:

Response from NA-83.

Response data are ASCII.

<STX>	01H	ATTR	Response data	<ETX>	BCC	<CR>	<LF>
1	1	1	N	1	1	1	1 byte

\* ATTR = 'A' or 'Q'

When there are multiple parameters, a comma “,” is used as delimiter.

Acknowledge response block:

Response from NA-83

<STX>	01H	ATTR	<ETX>	BCC	<CR>	<LF>
1	1	1	1	1	1	1 byte

\* ATTR = <ACK>

Not Acknowledge response block:

Response from NA-83

<STX>	01H	ATTR	Error code	<ETX>	BCC	<CR>	<LF>
1	1	1	4	1	1	1	1 byte

\* ATTR = <NAK>

Stop request code:

Computer

<SUB>
1 byte

This section explains the functions of “ATTR” and “BCC” in the transfer format block.

### ATTR: Block Attribute

The block attribute information is added by the sender, to facilitate processing of the block at the receiving end.

Code		Description
<ACK>	06H	Acknowledge block
<NAK>	15H	Not Acknowledge block
<SUB>	1AH	Stop request block
‘C’	43H	Command block
‘A’	41H	Data response block (last block)
‘Q’	51H	Data response block (intermediate block)

### BCC: Block Check Code

The NA-83 calculates the following range and adds it as BCC to the send block.

Calculation range: From STX to ETX

Calculation method: 8 bits of exclusive OR sum of range

BCC from the computer is fixed to 00H (NULL).

## Block reception processing

For reception processing, the unit is initially in the <STX> wait (idling) mode, except during a sequence while waiting for response from the computer.

In idling mode, the NA-83 disregards any data except <STX>.

### Command types

There are two types of commands: setting commands and request commands.

#### Setting command

This type of command serves for changing the NA-83 status or measurement parameters. Only some commands of this type will produce a response.

For commands that have a response, this consists of status information returned after the setting command has been processed.

#### Request command

This type of command serves for getting information about unit settings and for obtaining measurement data. The NA-83 returns the requested data.

## Error processing

### Transmission errors

Transmission errors can be detected in the following categories.

Error item	Content	Processing step
Framing error	Character level framing error	Disregard character and wait for next character
Block reset	<STX> received after incomplete block	Start block again from that point

### Command processing errors

Block format is correct, but command interpretation or processing has resulted in an error.

Error item	Content	Processing step
Undefined command	Command problem	Return error code 0001
Parameter error	Parameter number or value not correct	Return error code 0002
Processing error	Processing cannot be carried out in current state	Return error code 0003
Processing timeout	Timeout interval has elapsed	Return error code 0004

## Transfer types

The types of transfer sequences are as follows.

- Setting sequence
- Request sequence
- Continuous request sequence
- Error sequence

## Setting sequence

Normal processing

An Acknowledge response is returned after command processing was initiated. “Initiated” means that execution of the command was started, but the process is not yet completed.



Error processing

When an error has occurred during block or command processing, a Not Acknowledge response is returned.

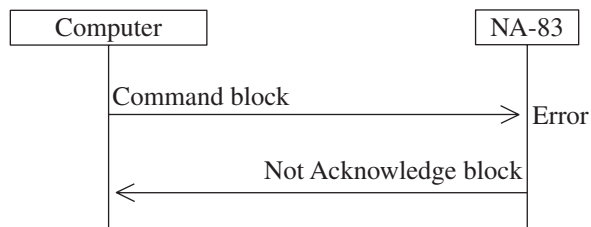

## Request sequence

### Normal processing

A response is returned immediately to the request command.

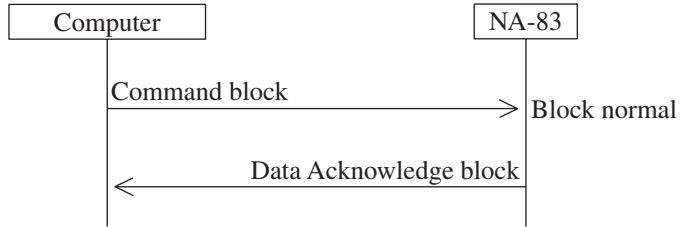

### Error processing

When an error has occurred during block or command processing, a Not Acknowledge response is returned.

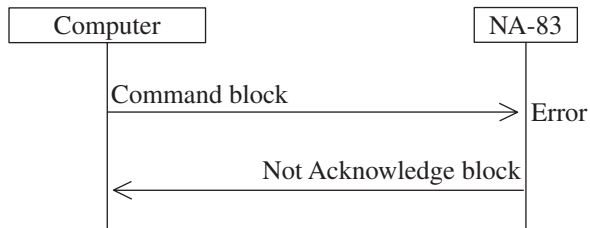



## Continuous request sequence (DRD command)

This sequence only applies to a command which initiates periodic sending of measurement data.

In general, there is no need for returning response codes from the computer. The NA-83 sends blocks continuously.

To stop the transmission, the computer sends the stop request code <SUB>. Any other commands received by the NA-83 are disregarded.

After stop mode was entered, the NA-83 goes into the idling state.

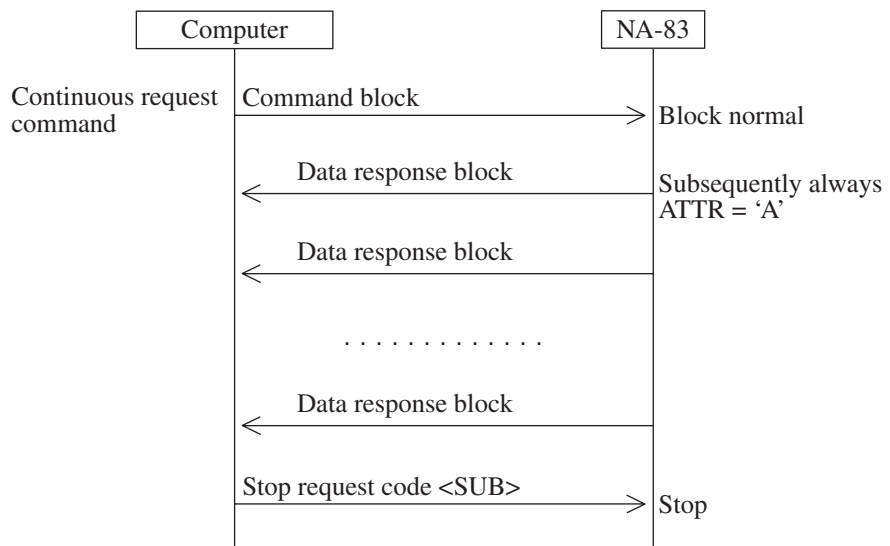

## Error sequence

When an error generating an error response on the block level has occurred, the error sequence is as follows.

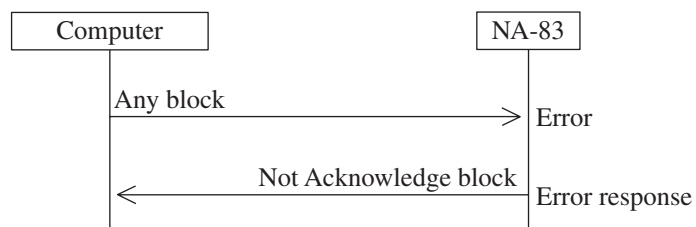

## Communication cutoff

To shut down communication, turn power to the NA-83 off.

## Ratings

Guaranteed values

Case	Rating	Remarks
NA-83 response time	Max. 3 s	Processing timeout error response if due to processing reasons
Send character interval	Max. 100 ms	----
Interval until NA-83 enters idling state when data have been sent	Max. 200 ms	----

Rated values

Case	Rating	Action if exceeded
Multiple block request sequence ACK wait	10 s	Pause sequence and go into idling state
Send timeout with flow control	3 s	Pause sequence and go into idling state
Block generation wait time after receiving <STX>	No limit	----
Receive character interval	No limit	----

# Commands

## Command list

### Measurement parameter related commands

WGT	Select frequency weighting .....	92
WGT?	Get frequency weighting setting .....	92
TMC	Select time weighting .....	92
TMC?	Get time weighting setting .....	92
OUT	Select AC/DC OUT setting .....	93
OUT?	Get AC/DC OUT setting .....	93
WSC	Select windscreen correction setting .....	93
WSC?	Get windscreen correction setting .....	93
MSM	Select microphone integrated sound source setting .....	94
MSM?	Get microphone integrated sound source setting .....	94
DSP	Switch measurement mode ( $L_p/L_{max}$ ) .....	94
DSP?	Get measurement mode ( $L_p/L_{max}$ ) .....	94

### Calibration/operation check related commands

CAL	Select calibration/operation check mode .....	95
CAL?	Get calibration/operation check mode setting .....	95
CBM	Adjust sensitivity (corresponds to CAL ADJ. keys ▲, ▼) ....	95
CBM?	Get sensitivity setting .....	95
CFR	Select frequency of microphone integrated sound source .....	96
CFR?	Get frequency of microphone integrated sound source .....	96

### Measurement data retrieval related commands

DOD?	Output measurement data as shown on display .....	96
DRD?	Continuous output of time-weighted sound level instantaneous value $L_p$ , maximum value $L_{max}$ , minimum value $L_{min}$ , and time average sound level $L_{eq}$ data .....	97

### Setting and information related commands

VER?	Get version information .....	98
DCL	Initialize (establish power-on default settings) .....	98
RMT	Set remote/local mode .....	98
RMT?	Get remote/local mode setting .....	98
EST?	Get most recent error code .....	99

## Command format

In this manual, 1 character is represented as “□”, a space as “\_”, parameters as “p1”, and response data as “d1,d2,...”. Response data may be more than 1 character long.

Commands consists of three letters which are not case-sensitive (upper-case or lower-case can be used).

□□□

When a command has a parameter, the parameter follows the command. It can be appended to the command either directly or with a separating space.

□□□p1      Valid

□□□\_p1     Valid

Note
One command block can only contain one command. Do not include several commands in a block.

A request command consists of the command and a “?”. The command and “?” may be separated by a space.

□□□?      Valid

□□□\_?     Valid

## Error codes

Error code	Meaning
0001	Undefined command or other command problem
0002	Parameter number or value not valid
0003	Processing not possible in current state
0004	Processing completion timeout interval has elapsed

## Command send example

To set frequency weighting to “C”

<STX>	01 <sub>H</sub>	C	WGT	1	<ETX>	00 <sub>H</sub>	<CR><LF>
(1)	(2)	(3)	(4)	(5)	(6)	(7)	(8)

(1) Start of transfer data and command    Always <STX>

(2) Always 01<sub>H</sub> (equivalent to 1)

Note
Do not use ASCII “01” here. Express “01” in 2-digit hexadecimal notation, i.e. “01” (01 <sub>H</sub> ).

(3) Attribute (“C” for command)            Always C

(4) Command                                    3 alpha characters

(5) Parameter (corresponds to p1 in command description section of manual [following pages])

(6) Command end                                Always <ETX>

(7) Always 00<sub>H</sub>

(8) Transfer data end                           Always <CR><LF>

## Command description

### Measurement parameter related commands

#### WGT

Select frequency weighting

WGTp1

p1 = 0: A-weighting

p1 = 1: C-weighting

p1 = 2: Z-weighting

Transfer format: Command block

Get frequency weighting setting

WGT?

NA-83 response data to WGT?

Response data d1

d1: Corresponds to p1

Transfer format: Response block

\* This command is valid only in the normal measurement condition ( $L_p$ ).  
At other times, error code 0003 is returned.

#### TMC

Select time weighting

TMCp1

p1 = 0: F (Fast)

p1 = 1: S (Slow)

Transfer format: Command block

Get time weighting setting

TMC?

NA-83 response data to TMC?

Response data d1

d1: Corresponds to p1

Transfer format: Response block

\* This command is valid only in the normal measurement condition ( $L_p$ ).  
At other times, error code 0003 is returned.

## OUT

Select AC/DC OUT setting

OUTp1

p1 = 0: AC OUT

p1 = 1: DC OUT

Transfer format: Command block

Get AC/DC OUT setting

OUT?

NA-83 response data to OUT?

Response data d1

d1: Corresponds to p1

Transfer format: Response block

\* This command is valid only in the normal measurement condition ( $L_p$ ).

At other times, error code 0003 is returned.

## WSC

Select windscreen correction setting

WSCp1

p1 = 0: OFF (no correction)

p1 = 1: ON (correction enabled)

Transfer format: Command block

Get windscreen correction setting

WSC?

NA-83 response data to WSC?

Response data d1

d1: Corresponds to p1

Transfer format: Response block

\* This command is valid only in the normal measurement condition ( $L_p$ ).

At other times, error code 0003 is returned.

## MSM

Select microphone integrated sound source setting

MSMp1

p1 = 0: OFF (sound source not used)

p1 = 1: ON (sound source used)

Transfer format: Command block

Get microphone integrated sound source setting

MSM?

NA-83 response data to MSM?

Response data d1

d1: Corresponds to p1

Transfer format: Response block

\* This command is valid only in the normal measurement condition ( $L_p$ ).  
At other times, error code 0003 is returned.

## DSP

Switch measurement mode ( $L_p/L_{\max}$ )

DSPp1

p1 = 0:  $L_p$

p1 = 1:  $L_{\max}$

Transfer format: Command block

Get measurement mode ( $L_p/L_{\max}$ )

DSP?

NA-83 response data to DSP?

Response data d1

d1: Corresponds to p1

Transfer format: Response block

\* The setting command is valid only in the normal measurement condition ( $L_p$ ) or maximum value measurement condition ( $L_{\max}$ ). At other times, error code 0003 is returned.



## Calibration/operation check related commands

### CAL

Select calibration/operation check mode

CALp1

p1 = 0: Cancel calibration/operation check mode

p1 = 1: Calibration with external sound calibrator

p1 = 2: Calibration/operation check with microphone integrated sound source

\* Valid only when microphone integrated sound source setting (MSM) is ON

p1 = 3: Electrical calibration of NA-83 unit only, using internal signal generator (1 kHz, sinusoidal wave)

\* Valid only when microphone integrated sound source setting (MSM) is OFF

Transfer format: Command block

Get calibration/operation check mode setting

CAL?

NA-83 response data to CAL?

Response data d1

d1: Corresponds to p1

Transfer format: Response block

\* This command is valid only in the normal measurement condition ( $L_p$ ) or calibration condition. At other times, error code 0003 is returned.

### CBM

Adjust sensitivity (corresponds to CAL ADJ. keys ▲, ▼)

CBMp1

p1 = 0: Gain DOWN (▼)

p1 = 1: Gain UP (▲)

Transfer format: Command block

Get sensitivity setting

CBM?

NA-83 response data to CBM?

Response data d1

d1: 118 to 880 (irregular steps)

Transfer format: Response block

\* The setting command is valid only in the calibration condition. At other times, error code 0003 is returned.

## CFR

Select frequency of microphone integrated sound source

CFRp1

p1 = 0: 250 Hz

p1 = 1: 500 Hz

p1 = 2: 1 kHz

p1 = 3: 4 kHz

Transfer format: Command block

Get frequency of microphone integrated sound source

CFR?

NA-83 response data to CFR?

Response data d1

d1: Corresponds to p1

Transfer format: Response block

\* This command is valid in all conditions.

## Measurement data retrieval related commands

### DOD?

Output measurement data as shown on display

DOD?

NA-83 response data to DOD?

Response data d1,d2,d3

d1: Display data

Data are expressed as 3-digit or 4-digit numeral

Examples: for 75.0 dB: d1 = 750

for 121.5 dB: d1 = 1215

d2: Over-range information

d2 = 0: No over-range data included

d2 = 1: Over-range data included

d3: Under-range information

d3 = 0: No under-range data included

d3 = 1: Under-range data included

Transfer format: Response block

\* This command is valid in all conditions.

## DRD?

Continuous output of time-weighted sound level instantaneous value  $L_p$ , maximum value  $L_{\max}$ , minimum value  $L_{\min}$ , and time average sound level  $L_{\text{eq}}$  data for every 100 ms.

### DRD?

NA-83 response data to DRD?

Response data d1,d2,...,d9

d1: Instantaneous value  $L_p$  with time weighting F, for every 100 ms

Data are expressed as 3-digit or 4-digit numeral

Examples: for 75.0 dB: d1 = 750

for 121.5 dB: d1 = 1215

d2: Maximum value  $L_{\max}$  with time weighting F, for every 100 ms

Data are expressed as 3-digit or 4-digit numeral

d3: Minimum value  $L_{\min}$  with time weighting F, for every 100 ms

Data are expressed as 3-digit or 4-digit numeral

d4: Instantaneous value  $L_p$  with time weighting S, for every 100 ms

Data are expressed as 3-digit or 4-digit numeral

d5: Maximum value  $L_{\max}$  with time weighting S, for every 100 ms

Data are expressed as 3-digit or 4-digit numeral

d6: Minimum value  $L_{\min}$  with time weighting S, for every 100 ms

Data are expressed as 3-digit or 4-digit numeral

d7: Time-average sound level  $L_{\text{eq}}$  for every 100 ms

Data are expressed as 3-digit or 4-digit numeral

d8: Over-range information

d8 = 0: No over-range data included

d8 = 1: Over-range data included

d9: Under-range information

d9 = 0: No under-range data included

d9 = 1: Under-range data included

Transfer format: Response block

\* This command is valid in all conditions.

To stop data output, send the stop request code <SUB>.

While data output is active, any other command besides <SUB> is ignored.

## Setting and information related commands

### VER?

Get version information

#### VER?

NA-83 response data to VER?

Response data d1

d1: X.Y system version

Transfer format: Response block

\* This command is valid in all conditions. It has no setting command.

### DCL

Initialize (establish power-on default settings)

#### DCL

There are no setting parameters.

Transfer format: Command block

\* This command is valid only in the normal measurement condition ( $L_p$ ).

At other times, error code 0003 is returned.

### RMT

Set remote/local mode

#### RMTp1

p1 = 0: Set to local mode

p1 = 1: Set to remote mode

Transfer format: Command block

Get remote/local mode setting

#### RMT?

NA-83 response data to RMT?

Response data d1

d1 = Corresponds to p1

Transfer format: Response block

\* This command is valid in all conditions.

## EST?

Get most recent error code

EST?

NA-83 response data to EST?

Response data d1

d1: Error code (see page 91)

Transfer format: Response block

\* This command is valid in all conditions.

## Example for control via external commands

An example for controlling operation of the sound level meter via commands is shown below.

To check whether a setting was made properly, using a request command after sending a setting command is recommended.

Example: Get measurement data

(Frequency weighting: C, time weighting: S, windscreen correction: ON)

Power-on



Setting

- WGT1	(frequency weighting: C)
- TMC1	(time weighting: S)
- WSC1	(windscreen correction: ON)



DOD? (Get data shown on display)

DRD? (Get measurement data continuously every 100 ms)

Stop data output from NA-83 with <SUB>

